



NORCOOL PRODUCT CATALOG

Follow us on social media

 [scandinavianappliancesnorcool](#)

 [norcool.appliances](#)



Scandinavian Appliances AS
Fourth issue, November 2025

Design and production: Konsis Grafisk AS
Økernveien 121, 0579 Oslo
www.konsis.no

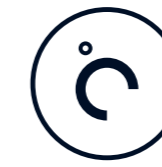

01 ABOUT NORCOOL

6



02 CORNER FRIDGE

8



03 DRAWER FRIDGE

14



04 DRAWER FREEZER

20



05 WINE

26



06 UNITS, DOORS &
COLD STORES

56



01

ABOUT NORCOOL

Since 1978, Norcool has supplied first-class cooling solutions to the consumer and business market. Even back then, with focus on quality and design – a focus that is still reflected in all products today.

As one of Scandinavia's leading cooling suppliers, our vision is to help you create a kitchen with solutions that inspire and spark joy every day. We deliver everything

you need to lift your kitchen to the next level – cold stores and corner fridges, drawer fridges, cooling units and wine storage solutions.

With refrigeration solutions tailored to your kitchen, the possibilities for storing food and drinks are almost endless. Let yourself be inspired – it has never been easier!



02

CORNER FRIDGE

Are you tired of your full, cluttered fridge? Then our large, best-selling Corner Fridge could be what you're looking for.

The Corner Fridge is both spacious and space-efficient, and has that extra space for everything you need – big and small, wet and dry. In addition to this, the clear, transparent glass shelves allows for a full overview.

With this Corner Fridge, you're simply investing in more space, a full overview of your ingredients, and less food waste. Storage and cooking has never been easier.

CORNER FRIDGE

With this Corner Fridge, the time of the cluttered refrigerator is over.

This Corner Fridge is among the largest refrigerators on the market, with a capacity of a whopping 1195 liters – equivalent to the size of 3-4 regular refrigerators. It has a low energy consumption, and can be delivered either as a free-standing unit or integrated into the kitchen. The choice is yours.

PRODUCT ADVANTAGES

- 3m² of shelf space in tempered glass
- Neat and well-organized interior
- Silent and maintenance-free technology
- Integrates with all types of kitchens
- Temperature range: 2-10 °C



Model	Item number
Corner Fridge for kitchen integration	60000015

Dimensions	
External dimensions	1015 x 1015 mm
Niche dimensions	2110-2140 mm
Volume	1195 liters
Weight	Approx. 165 kg
For intergration	Yes
Power cable	3,6 meters

Noise	
Noise level	38 dB

Temperaturee	
Termostat setting	2-10°C
Ambient temperature	16-38°C
Defrosting	Automatic

Accessories	Item number
Floor protector inside	9947551200
Ventilation grille 65 x 460 mm, aluminum	1137990970
Ventilation grille 65 x 460 mm, black*	9958550080
Ventilation grille 65 x 460 mm, white	9958550090

Energy	
Consumption	169,73 kWh/year
Energry class	D
Lighting	2 x LED 7,9 W

Shelves	
Number of shelves	5
Material	Glass and wire shelves

Door hinging	
Optional right/left	

Ventilation	
Requires ventilation	Ventilation grille in floor and ceiling plinth

* Black ventilation grille is delivered as a standard.

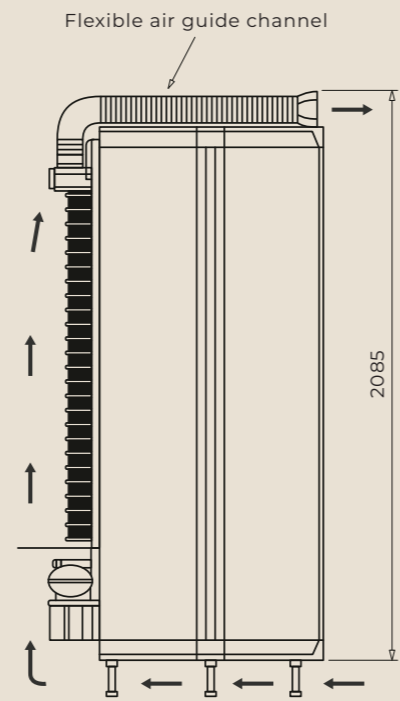
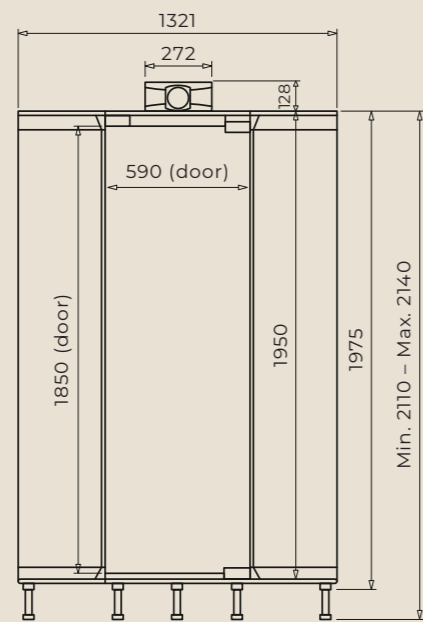
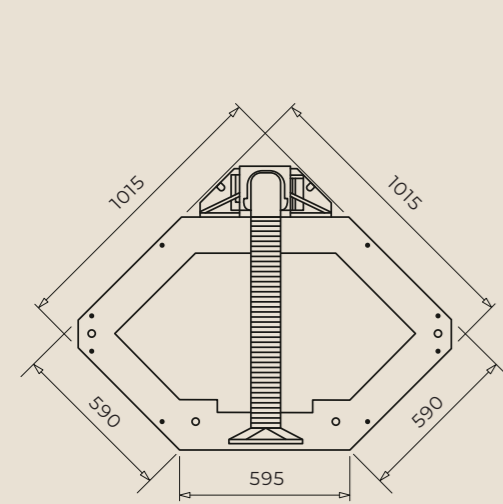

All dimensions are listed in millimeters.





03

DRAWER FRIDGE

Do you dream of an open and airy kitchen with lots of counter space? A kitchen that feels tidy and organized, and invites togetherness? Then our innovative Drawer Fridge is made for you.

Hide the refrigerator in the kitchen island or along the wall – whatever suits you best. With these drawers you get everything – an open kitchen solution and all the storage you need.

With our delicate Drawer Fridge, the usual large refrigerator is moved down into integrated kitchen drawers, without compromising on space or efficiency.

DRAWER FRIDGE

The new generation of the Drawer Fridge is perfect for the modern, minimalist kitchen with open spaces and lots of counter space.

With this practical unit, your cooled items are placed in two large drawers integrated under the kitchen counter. The drawers are spacious, well organized and free up space on the kitchen counter. A dream for those who want more counter space!

Choose between fronts in black matte, stainless steel, or in the same style as the kitchen furnishings you already have.

PRODUCT ADVANTAGES

- More counter space and easier access to the goods
- Practical solution for wheelchair users and easy accessibility for children
- Integrates with all types of kitchens
- Choose between three different fronts: furniture front, steel or black matte
- Two large drawers plus one smaller drawer
- Maintenance-free with automatic defrosting
- Digital thermostat
- LED light
- Door alarm
- Powerful intake
- Adjustable legs for easier installation



Model	Item number
Drawer Fridge for for attaching a furniture front	60000006

Dimensions	
External dimensions	W795 x H820-870 x D565 mm
Niche dimensions	W800 x H825 (min.) x D565 mm
Volume	104 liters
Weight	65 kg
For integration	Yes
Power cable	2,4 meters

Noise	
Noise level	37 dB

Temperature	
Thermostat setting	2-10°C
Ambient temperature	16-32°C
Defrosting	Automatic

Accessories	Item number
Front panel, black matte	8900013831
Front panel, steel	8900013832

Energy	
Consumption	116,44 kWh/year
Energy class	D
Lighting	LED light

Drawers	
Number of drawers	2 large drawers + 1 smaller drawer inside
Alarm	Yes, turns on after 30 seconds

Front panel	
Furniture front, steel front or black matte front	

Ventilation	
Requires ventilation	Ventilation grille in the floor plinth – included

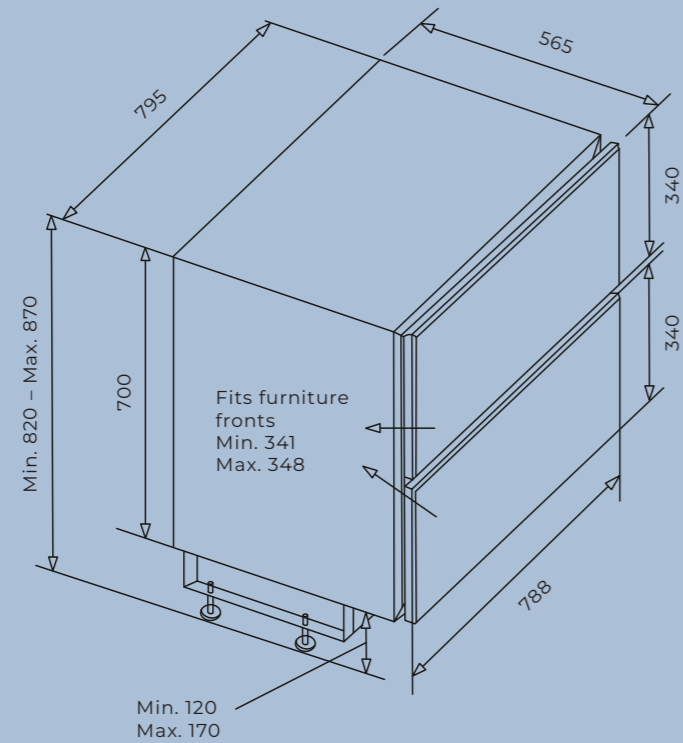

All dimensions are listed in millimeters.

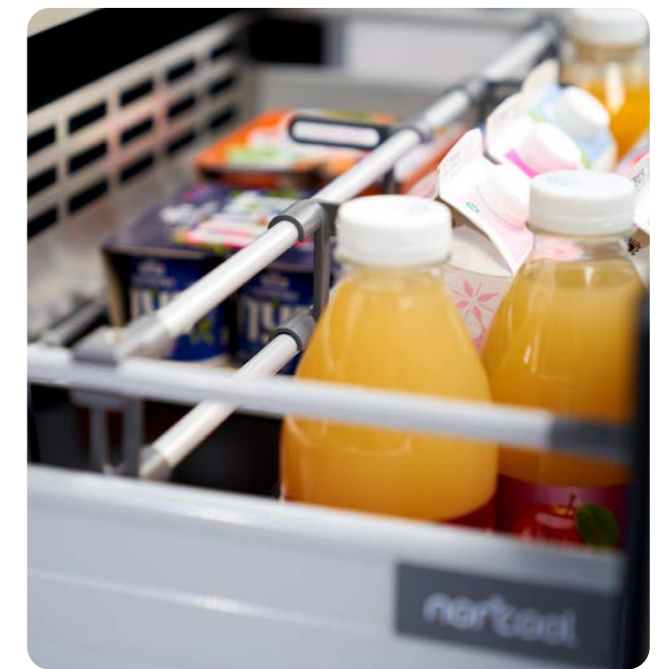



04

DRAWER FREEZER

Are you looking for a solution that gives you more space and a more streamlined kitchen? A kitchen where functionality meets aesthetics, and where it is easy to keep things in order? Our Drawer Freezer gives you the freedom to integrate the freezer in a discreet and elegant way, without compromising storage space.

With the freezer placed in practical drawers, you can make better use of the kitchen island or walls, whichever suits your kitchen style.

With the Drawer Freezer you get both an open, spacious kitchen and plenty of freezing capacity – tailored to your everyday life.

DRAWER FREEZER

The Drawer Freezer is ideal for modern homes, and can be seamlessly integrated into your kitchen decor.

Equipped with two spacious drawers, the Drawer Freezer gives you easy access and a perfect overview of your frozen goods. Everything is conveniently located where you need it most, whether you are preparing everyday dinners or festive meals. You can choose whether you want the front to be black matt, in stainless steel or in the same style as your kitchen decor.

With the Drawer Freezer, your cooking experience becomes both practical and stylish.

PRODUCT ADVANTAGES

- Practical solution for wheelchair users and easy accessibility for children
- Integrates with all types of kitchens
- Choose between three different fronts: furniture front, steel or black matte
- Maintenance-free with automatic defrosting
- Digital thermostat
- LED light
- Door alarm
- Adjustable legs for easier installation



Model	Item number
Drawer Freezer	60000008

Dimensions	
External dimensions	W795 x H820-870 x D565 mm
Niche dimensions	W800 x H825 (min.) x D570 mm
Volume	104 liters
Weight	70 kg
For integration	Yes
Power cable	2,4 meters

Noise	
Noise level	38 dB

Temperature	
Thermostat setting	-18/-24°C
Ambient temperature	16-32°C
Defrosting	Automatic

Accessories	Item number
Front panel, black matte	8900013831
Front panel, steel	8900013832

Energy	
Consumption	329 kWh/year
Energy class	D
Lighting	LED light
Gas	R600 A

Drawers	
Number of shelves	2 large drawers
Alarm	Yes, turns on after 30 seconds

Front panel	
Furniture front, steel front or black matte front	

Ventilation	
Requires ventilation	Ventilation grille in the floor plinth – included

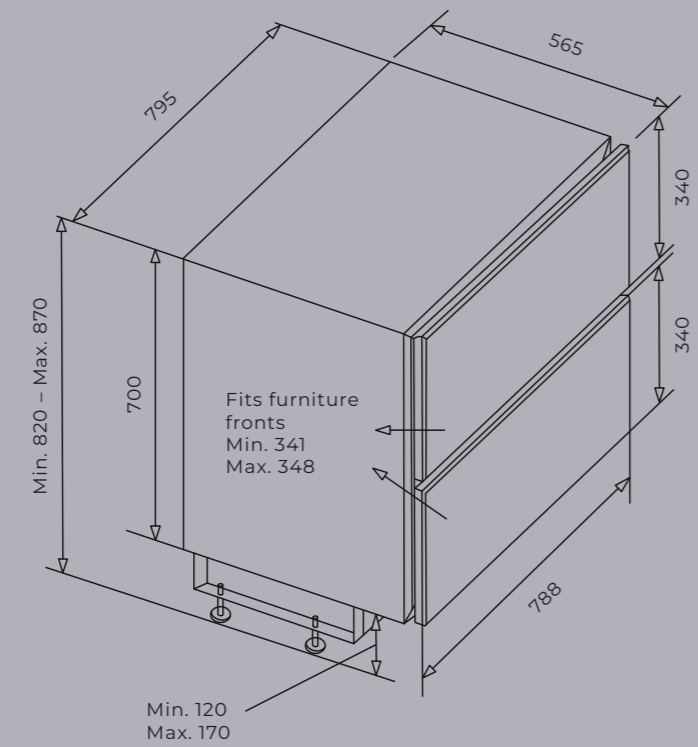

All dimensions are listed in millimeters.





05

WINE

A wine cabinet is a must for all wine lovers. Correctly tempered wine creates the optimal taste experience and makes good wine even better.

At least don't let lack of space stop you! By investing in a wine cabinet you invest in better wine and even better experiences.

With our range of models, everyone can fit a wine cabinet in their home, big or small. Our wine cabinets fit perfectly under the kitchen counter as part of the furnishings. We also have wine cabinets that slide straight into the tall cabinet. The choice is yours.

WINE DRAWER

This elegant Wine Drawer is designed to seamlessly integrate under the kitchen countertop, offering a perfect blend of style and functionality.

With space for 44 standard 75 cl wine bottles, the Wine Drawer ensures your wine collection is optimally preserved and easily accessible. It is equipped with a digital thermostat for precise temperature control, LED lighting to elegantly highlight your wine collection, and a door alarm to ensure no valuable cooling is lost. Whether preparing a dinner for friends or enjoying a glass in peace, the Wine Drawer is the perfect solution for storing and showcasing your wine in style.

Preserve, display, and celebrate with the Wine Drawer – elegance and accessibility at your fingertips.

PRODUCT ADVANTAGES

- Space-efficient
- Fits up to 44 wine bottles
- Elegant design
- Tinted and tempered glass with UV-protection
- Pull-out shelves
- LED light and digital display
- Adjustable legs for easier installation
- Integrates with all types of kitchens
- Temperature range: 4-22°C



Model	Item number
Wine Drawer	60000007

Dimensions	
External dimensions	W795 x H820-870 x D565
Niche dimensions	W800 x H825 x D570 (min.)
Weight	77 kg
Capacity	Approx. 44 standard 75 cl wine bottles
For integration	Yes
Power cable	2,4 meters

Noise	
Noise level	38 dB

Temperature	
Number of cooling zones	1
Thermostat setting	4-22°C
Ambient temperature	16-32°C
Defrosting	Automatic

Energy	
Consumption	96 kWh/year
Energy class	D
Lighting	LED light

Drawers	
Number of drawers	5
Material	Rubberized metal
Glass	Tempered safety glass with UV protection
Alarm	Yes, turns on after 30 seconds

Ventilation	
Requires ventilation	Ventilation grille in floor plinth – included

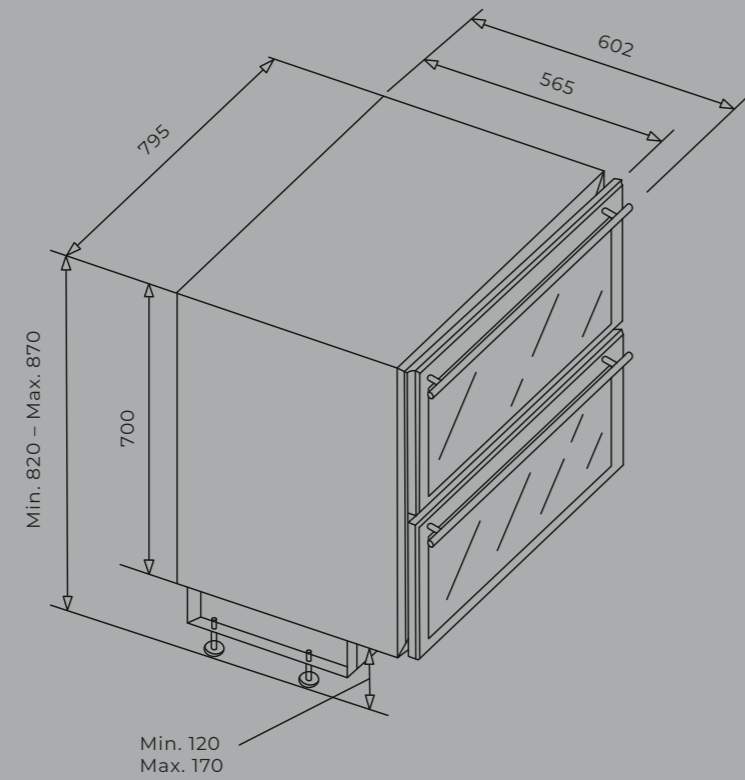

All dimensions are listed in millimeters.

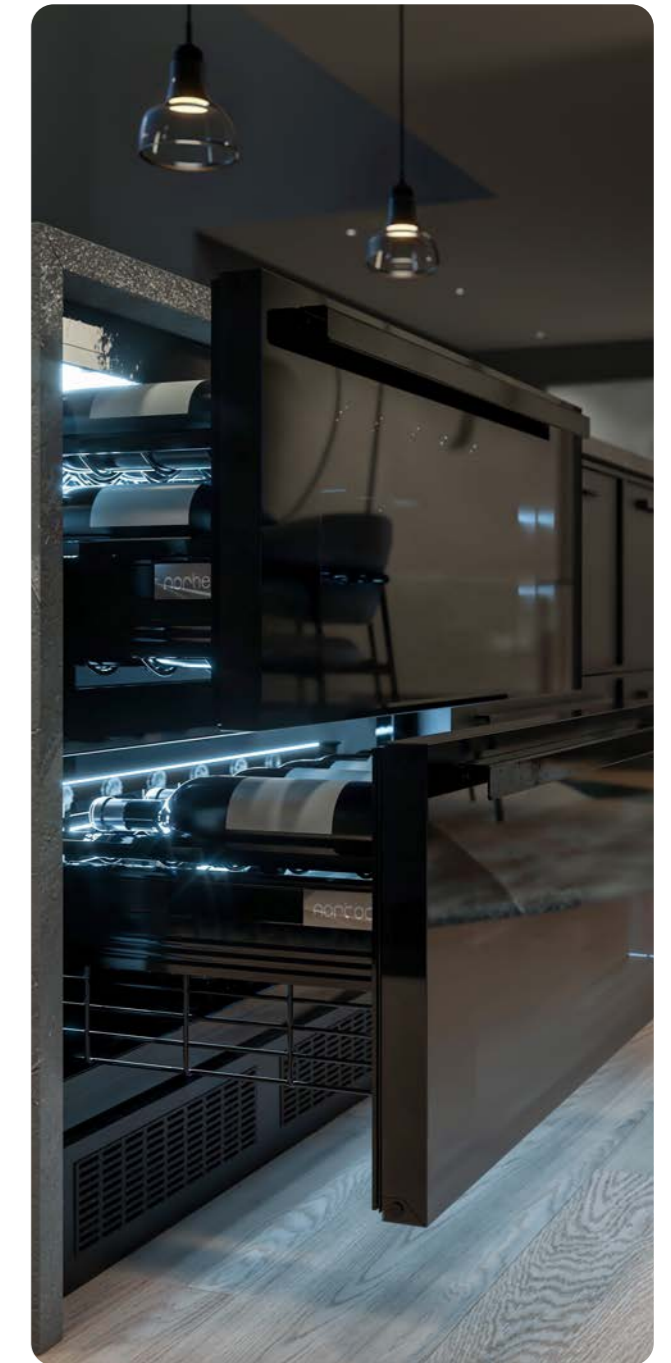

CAVE 30 BU DZ

Are you a wine-lover but have limited space in your kitchen? No problem!

Our smart, compact wine cabinet fits perfectly under the worktop, making it simple to integrate with your kitchen layout. At just 30 cm wide it takes up little space, but it still boasts a wide range of features: it can store around 18 bottles of standard 75 cl size, but also ensures that the wine is kept at the perfect temperature, no matter whether you are stocking up on red, white or rosé.

The smart choice when space is at a premium.

PRODUCT ADVANTAGES

- Space-efficient
- Fits up to 18 wine bottles
- Elegant design
- Tinted and tempered glass with UV-protection
- Pull-out wooden shelves
- LED light and digital display
- Discreet plinth and adjustable legs
- Integrates with all types of kitchens
- Temperature range: 4-22°C



This product is an integrated cabinet that should be installed into a kitchen with a plinth. Not a free-standing unit.

Model	Item number
Cave 30 BU DZ	12700030

Dimensions	
External dimensions	W295 x H820-880 x D575 mm
Niche dimensions	W300 x H820 (min.) x D580 mm
Weight	32 kg
Capacity	Approx. 18 standard 75 cl wine bottles
For integration	Yes
Power cable	2 meters

Noise	
Noise level	39 dB

Temperature	
Number of cooling zones	2
Thermostat setting	4-12°C in the upper zone and 12-22°C in the lower zone
Ambient temperature	16-38°C
Defrosting	Automatic

** Aluminum ventilation grille is delivered as a standard.*

Accessories	Item number
Ventilation grille 110 x 250 mm, aluminum*	1137993670
Ventilation grille 110 x 250 mm, black	9958550100
Ventilation grille 110 x 250 mm, white	9958550110

Energy	
Consumption	135 kWh/year
Energy class	G
Lighting	LED 1 W

Shelves	
Number of shelves	5
Material	Wood

Doors	
Door hinge	Right-hinged. Can be rehung
Door glass	Tempered safety glass with UV protection
Door alarm	Yes, turns on after 30 seconds

Ventilation	
Requires ventilation	Ventilation grille in floor plinth

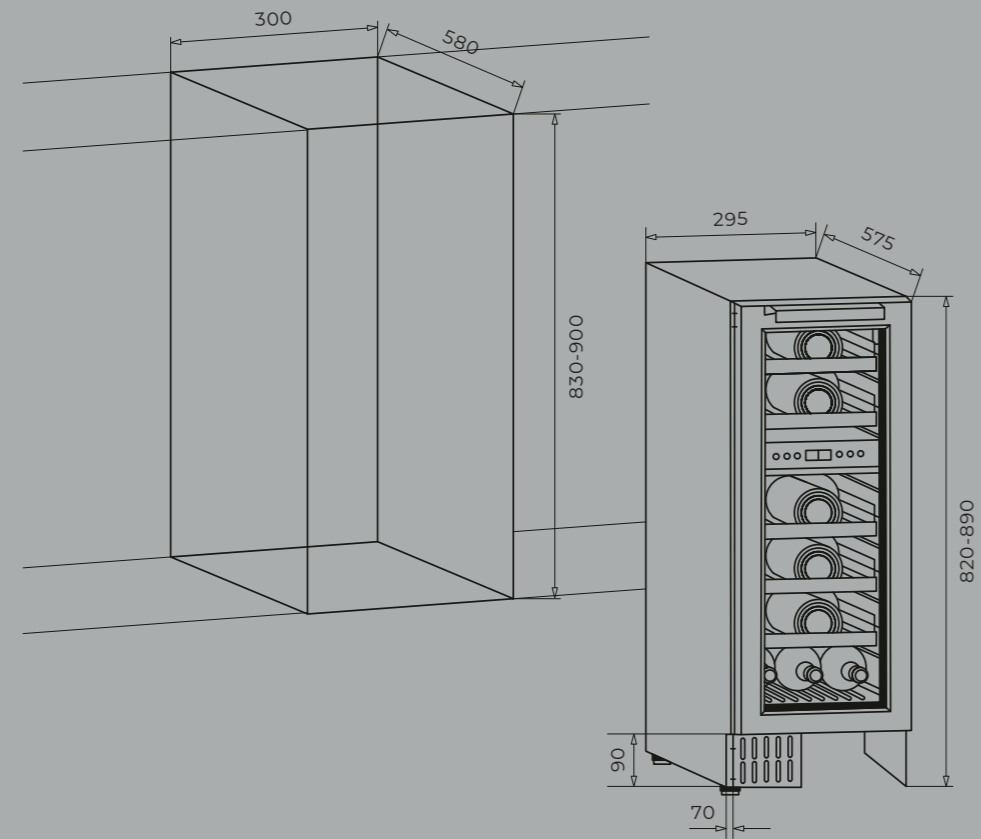

All dimensions are listed in millimeters.



CAVE 60 BU DZ & CAVE 60 BU DZ D

Have your cake and eat it too – a wine cabinet with plenty of room, and space under the kitchen counter!

This wine cabinet is spacious, elegant, and can be integrated with any type of kitchen furnishing. Choose between a single, right-hinged door or double doors. With its 60 cm width, the cabinet holds up to 46 wine bottles in two different temperature zones at 4–12 °C and 12–22 °C.

Plenty of room for your wine and perfect temperature, regardless of wine type or grape!

PRODUCT ADVANTAGES

- Space-efficient
- Fits up to 46 wine bottles
- Elegant design
- Tinted and tempered glass with UV-protection
- Pull-out wooden shelves
- LED light and digital display
- Discreet plinth and adjustable legs
- Integrates with all types of kitchens
- Temperature range: 4-22°C

This product is an integrated cabinet that should be installed into a kitchen with a plinth. Not a free-standing unit.



Model	Item number
Cave 60 BU DZ	12700060
Cave 60 BU DZ D	12700065

Dimensions	
External dimensions	W595 x H820 – 880 x D575 mm
Niche dimensions	W600 x H820 (min.) x D580 mm
Weight	48 kg
Capacity	Approx. 46 standard 75 cl wine bottles
For integration	Yes
Power cable	2 meters

Noise	
Noise level	39 dB

Temperature	
Number of cooling zones	2
Thermostat setting: Cave 60 BU DZ	4-12°C in the upper zone and 12-22°C in the lower zone
Thermostat setting: Cave 60 BU DZ D	4-12°C in left and right zone
Ambient temperature	16-38°C
Defrosting	Automatic

Energy - Cave 60 BU DZ	
Consumption	142 kWh/year
Energy class	G
Lighting	LED 1 W

* Aluminum ventilation grille is delivered as a standard.

Accessories	Item number
Ventilation grille 65 x 460 mm, aluminum*	1137990970
Ventilation grille 65 x 460 mm, black	9958550080
Ventilation grille 65 x 460 mm, white	9958550090

Energy - Cave 60 BU DZ D	
Consumption	175 kWh/year
Energy class	G
Lighting	LED 2 W

Shelves	
Number of shelves: Cave 60 BU DZ	5
Number of shelves: Cave 60 BU DZ D	11
Material	Wood

Doors	
Door hinge: Cave 60 BU DZ	Right-hinged. Can be rehung
Door hinge: Cave 60 BU DZ D	Double door. No adjustment options
Door glass	Tempered safety glass with UV protection
Door alarm	Yes, turns on after 30 seconds

Ventilation	
Requires ventilation	Ventilation grille in floor plinth

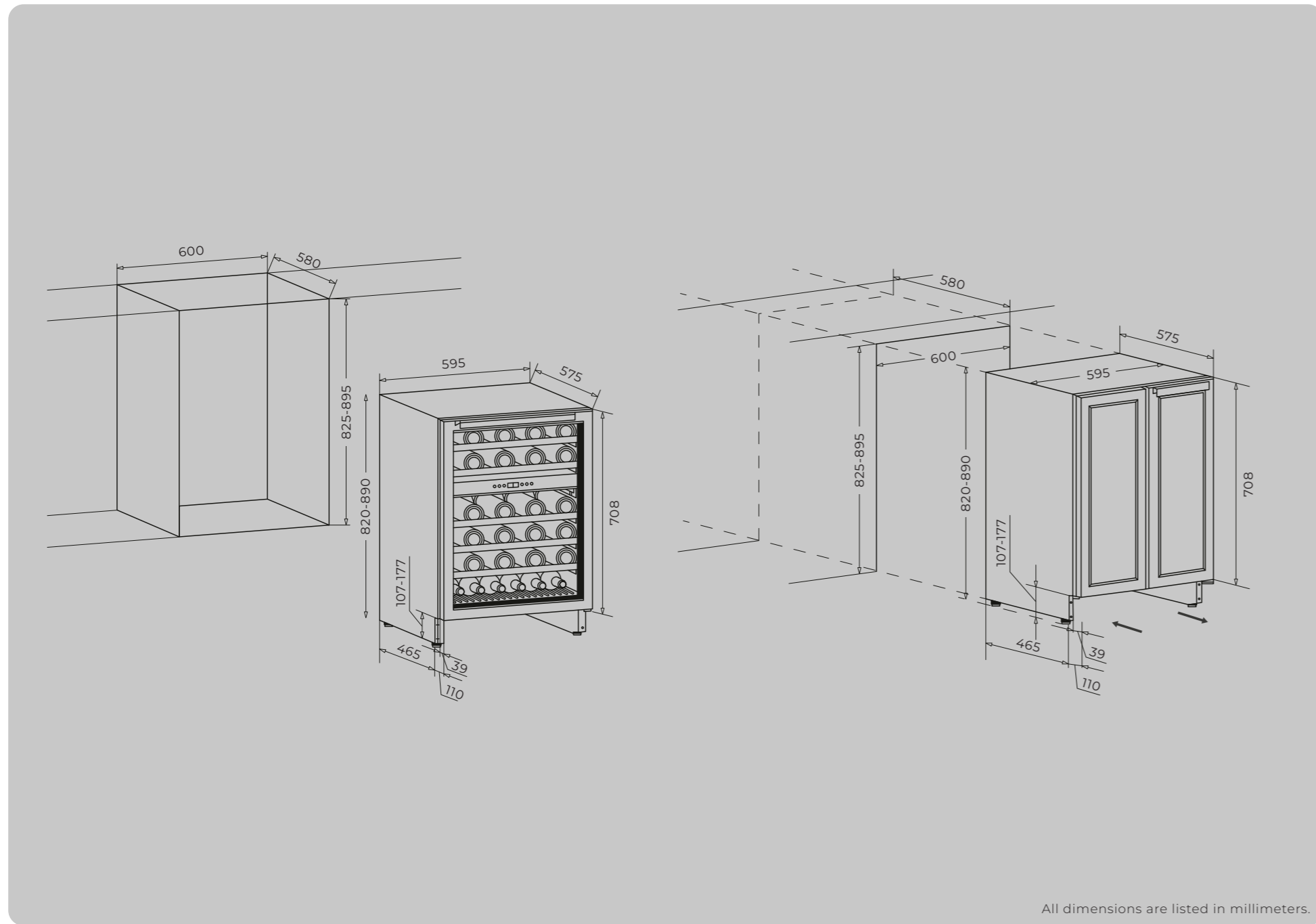

All dimensions are listed in millimeters.



CAVE 60 BI DZ

Are you looking for a wine cabinet for your high cabinet? Then please welcome Cave 60 BI DZ.

With this gorgeous wine cabinet you can store up to 28 wine bottles of standard 75 cl size. Whether your favorite wine is red or white, you can store all your bottles in perfect temperature on elegant, pull-out wooden shelves.

The wine cabinet has a digital thermostat, door alarm and LED lights, and you can set different temperatures ranging from 5-20 °C in both the upper and lower zone of the cabinet.

PRODUCT ADVANTAGES

- Space-efficient
- Fits up to 28 wine bottles
- Elegant design
- Tinted and tempered glass with UV-protection
- Pull-out wooden shelves
- LED light and digital display
- Adjustable legs
- Two temperature zones: 5-20°C in the upper and lower zone



This product is an integrated cabinet that should be installed into a kitchen with a plinth. Not a free-standing unit.

Model	Item number
Cave 60 BI DZ	12700260

Dimensions	
External dimensions	W590 x H593 x D555 mm
Niche dimensions	W562-568 x H590 x D555 mm
Weight	36 kg
Capacity	Approx. 28 standard 75 cl wine bottles
For integration	Must be integrated
Power cable	2 meters

Noise	
Noise level	37 dB

Temperature	
Number of cooling zones	2
Thermostat setting	5-20°C in the upper and lower zone
Ambient temperature	16-38°C
Defrosting	Automatic

Energy	
Consumption	135 kWh/year
Energy class	G
Lighting	LED 4 W

Shelves	
Number of shelves	3
Material	Wood

Doors	
Door hinge	Right-hinged. Can be rehung
Door glass	Tempered safety glass with UV protection
Door alarm	Yes, turns on after 30 seconds

Ventilation	
Requires ventilation	Ventilation grille in floor and ceiling plinth

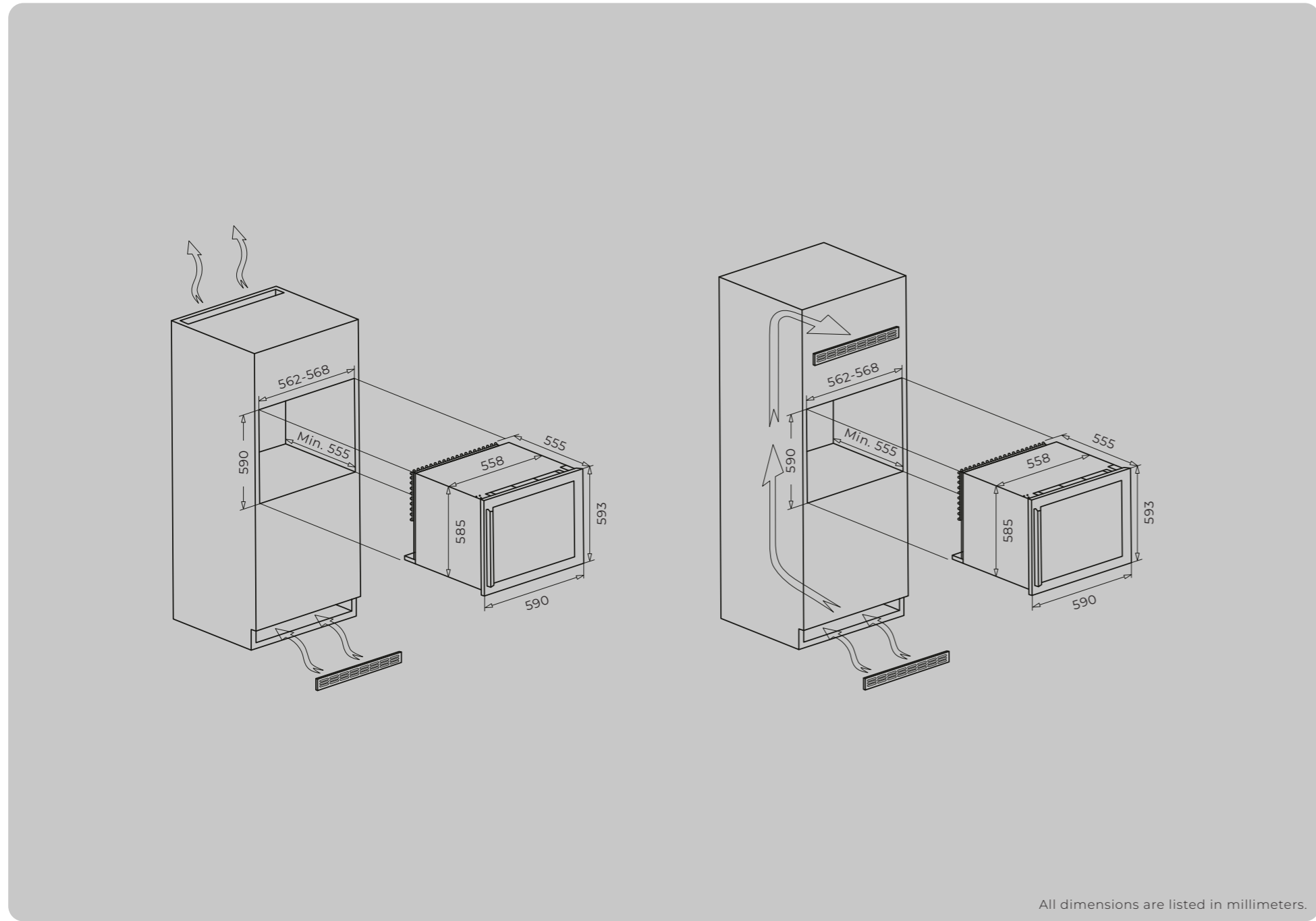

All dimensions are listed in millimeters.



CAVE 170 DZ

The wine collection in the spotlight: A spacious cabinet with display shelf, capacity for 163 bottles and customized temperature control.

Our biggest wine cabinet fits a total of 163 wine bottles – perfect for building up your wine collection. With its timeless design, wooden shelves and tinted glass, the wine cabinet has an exclusive feel to it. It has two temperature zones, from 4-22 °C, so both red and white wines can be perfectly tempered. Additionally the cabinet is free-standing, so you can easily place it where you want.

Take your wine collection to new heights with Cave 170 DZ!

PRODUCT ADVANTAGES

- Free-standing and flexible
- Fits up to 163 wine bottles
- Elegant design
- Tinted and tempered glass with UV-protection
- Pull-out wooden shelves
- Display shelf
- LED light and digital thermostat
- Two temperature zones from 4 to 22 °C
- Door lock



This product is a free-standing unit.

Model	Item number
Cave 170 DZ	12700170

Dimensions	
External dimensions	W595 x H1762 x D680 mm
Weight	90 kg
Capacity	163 standard 75 cl wine bottles
For integration	No, the unit is free-standing
Power cable	2 meters

Noise	
Noise level	39 dB

Temperature	
Number of cooling zones	2
Thermostat setting	4-12°C in the upper zone and 12-22°C in the lower zone
Ambient temperature	16-32°C
Defrosting	Automatic

Energy	
Consumption	201 kWh/year
Energy class	G
Lighting	LED 1+1 W

Shelves	
Number of shelves	8
Material	Wood

Doors	
Door hinge	Right-hinged. Cannot be rehung
Door glass	Tempered safety glass with UV protection
Door alarm	Yes

Ventilation	
Requires ventilation	No

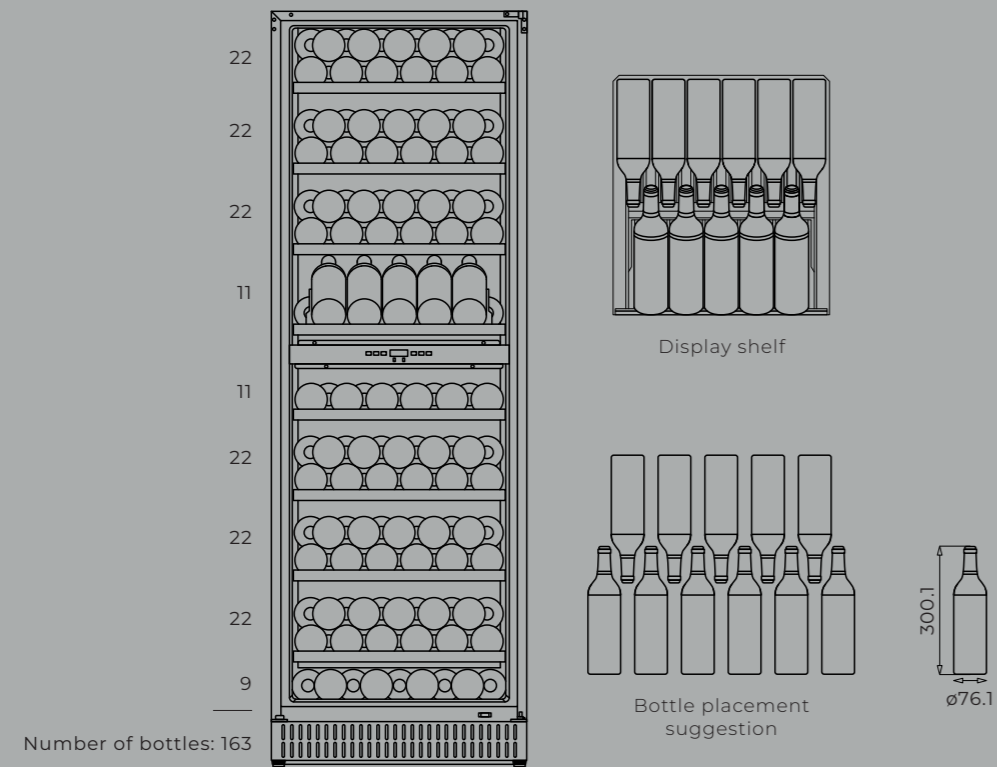

All dimensions are listed in millimeters.



CAVE 180 DZ

Get the most out of your wine collection: A spacious and stylish cabinet with room for a total of 159 bottles.

With its timeless design, wooden shelves and tinted glass, the wine cabinet has an exclusive feel to it. Experience the perfect temperature control with two zones that gives you the opportunity to create ideal conditions for both red and white wine, and enjoy an unparalleled taste experience. The wine cabinet has good storage capacity, with space for 159 wine bottles in standard 75 cl size. The cabinet is freestanding so you can easily place it wherever you want.

Discover a world of sophistication and functionality with this exclusive wine cabinet!

PRODUCT ADVANTAGES

- Free-standing and flexible
- Fits up to 159 wine bottles
- Elegant design
- Tinted and tempered glass with UV-protection
- Pull-out wooden shelves
- LED light and digital thermostat
- Two temperature zones from 4 to 22 °C
- Door lock



This product is a free-standing unit.

Model	Item number
Cave 180 DZ	12700180

Dimensions	
External dimensions	W595 x H1762 x D680 mm
Weight	90 kg
Capacity	159 standard 75 cl wine bottles
For integration	No, the product is free-standing
Power cable	2 meters

Noise	
Noise level	39 dB

Temperature	
Number of cooling zones	2
Thermostat setting	4-12°C in the upper zone and 12-22°C in the lower zone
Ambient temperature	16-32°C
Defrosting	Automatic

Energy	
Consumption	201 kWh/year
Energy class	G
Lighting	LED 1+1 W

Shelves	
Number of shelves	14
Material	Wood

Doors	
Door hinge	Right-hinged. Cannot be rehung
Door glass	Tempered safety glass with UV protection
Door alarm	Yes

Ventilation	
Requires ventilation	No

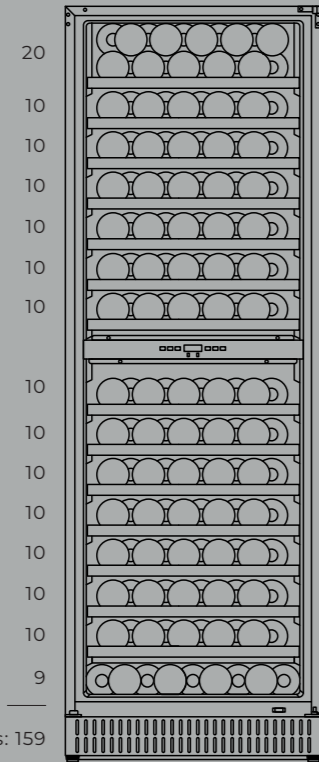

Number of bottles: 159

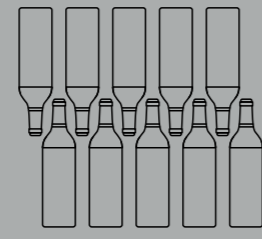

Bottle placement suggestion

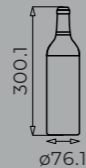

All dimensions are listed in millimeters.





06

UNITS, DOORS & COLD STORES

Do you find that the refrigerator you have today is not enough? Do you need more cooling and storage space than a Corner Fridge or Drawer Fridge has to offer? Then a cold store with a corresponding unit and door might be the solution for you.

With a cooling unit and one of our cold store solutions, you get all the space you need for storing both food and beverages, and even a little more.

Sometimes, all it takes is a big weekly shop to see your refrigerator filled to the bursting point. And then there are all the times you need a little extra space: let the turkey thaw overnight, store trays of soda and wine. These cold store solutions can handle everything.

Choose the size that meets your needs, and customize with the desired fronts.

COOLING UNITS

Are you opting for one of our smart, large cold stores? Then you'll also need a unit.

With one of our eco-friendly and energy-efficient units you can cool down all the space you need. The units are designed for cooling food and beverages at home, and come in three different volumes. (See the models for cold rooms and wine cellars from 5,000 to 20,000 liters).

The unit is placed in the wall between the cold room and a warmer room outside, and maintains a temperature between 2-18°C. Perfect for cooling and storing all food and beverages, including wine. What more could you dream of?



CU-350 ECO

PRODUCT ADVANTAGES

- Energy-efficient
- Easy to maintain
- Digital display
- Thermostat suitable for both food and wine
- Can connect to external lamp

	CU-350 ECO	CU-450 ECO	CU-900 ECO	CU-450 Split ECO
Item number	12600000	12600050	12600150	12600100
Dimensions				
External dimensions	W505 x H535 x D475 mm	W590 x H690 x D518 mm	W590 x H690 x D518 mm	Warm part: W590 x H690 x D315 mm Cold part: W537 x H360 x D221 mm
Wall cutout	W460 x H490 mm	W550 x H650 mm	W550 x H650 mm	-
Weight	28 kg	33 kg	37,5 kg	Warm part: 27 kg Cold part: 8,5 kg
Capacity	Up to 5.000 liters	Up to 10.000 liters	Up to 20.000 liters	Up to 20.000 liters
Max. pipe run	-	-	-	10 m
Max. wall thickness	330 mm	230 mm	230 mm	-
Min. distance to cold side of ceiling	100 mm	100 mm	200 mm	-
Min. distance to warm side of ceiling and floor	500 mm	500 mm	500 mm	-
Power cable	2,6 meters	2,6 meters	2,6 meters	2,6 meters
Noise				
Noise level	48,6 dB	49,3 dB	55 dB	55 dB
Temperature				
Thermostat setting	2-18°C	2-18°C	2-18°C	2-18°C
Ambient temperature	16-38°C	16-38°C	16-38°C	16-38°C
Defrosting	Automatic	Automatic	Automatic	Automatic
Energy				
Max. output	400 W	500 W	800 W	500 W
Lighting	LED 5 W	LED 6,5 W	LED 6,5 W	LED 6,5 W
Contact for external light	Max. 20 W LED	Max. 20 W LED	Max. 20 W LED	-
Miscellaneous				
Water overflow	Can be connected to a drain for extra safety	Can be connected to a drain for extra safety	Must be connected to drain	Must be connected to drain
Refrigerant	R290	R290	R290	R290

COLD STORE DOOR

D-1900

The self-builder door D-1900 is delivered complete with magnetic strip, frame profile, handles on both the inside and outside, hinge and screws. The door is placed on the outside and is sealed well with the magnetic strip.

This is a traditional self-builder door and is already seen in many Norwegian homes. You can have door hinges on both the right and left side, depending on your preference.

PRODUCT ADVANTAGES

- Can be hinged to the right and left
- Paintable surface



Model	Item number
D-1900	12663000
Dimensions	
Door leaf dimensions	W630 x H1900 x D50 mm
Light opening/recess inside the frame	W590 x H1860 mm
Door hinge	Optional right/left
Built-in heating cable	No
Door leaf weight	14 kg
Door handle	Delivered with handles on both sides

COLD STORES

Choose between four models of prefabricated cold stores, depending on the size you need. Whichever room you choose, you get a large storage capacity and smart solutions for storing both food and beverages.

The cold rooms are delivered with energy-saving sandwich elements, and can be placed wherever you want - in the kitchen, laundry room, storage room or basement.

PRODUCT ADVANTAGES

- Large storage capacity
- Four different models
- Easy to clean
- Delicate and light interior
- Foodsafe walls, floor and ceiling
- Delivered as flat-packed elements
- 100% protected against water damage and moisture
- Easy to assemble, disassemble or move
- Choose the standard interior package or a customizable one

Combination options for placement of door and unit.

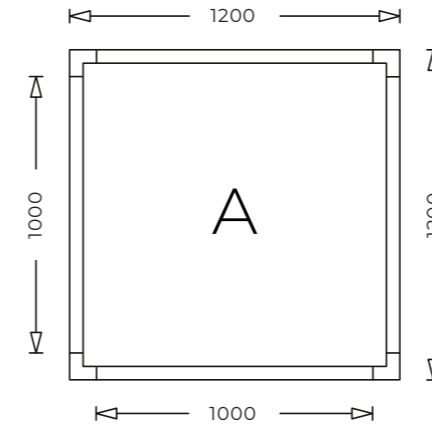
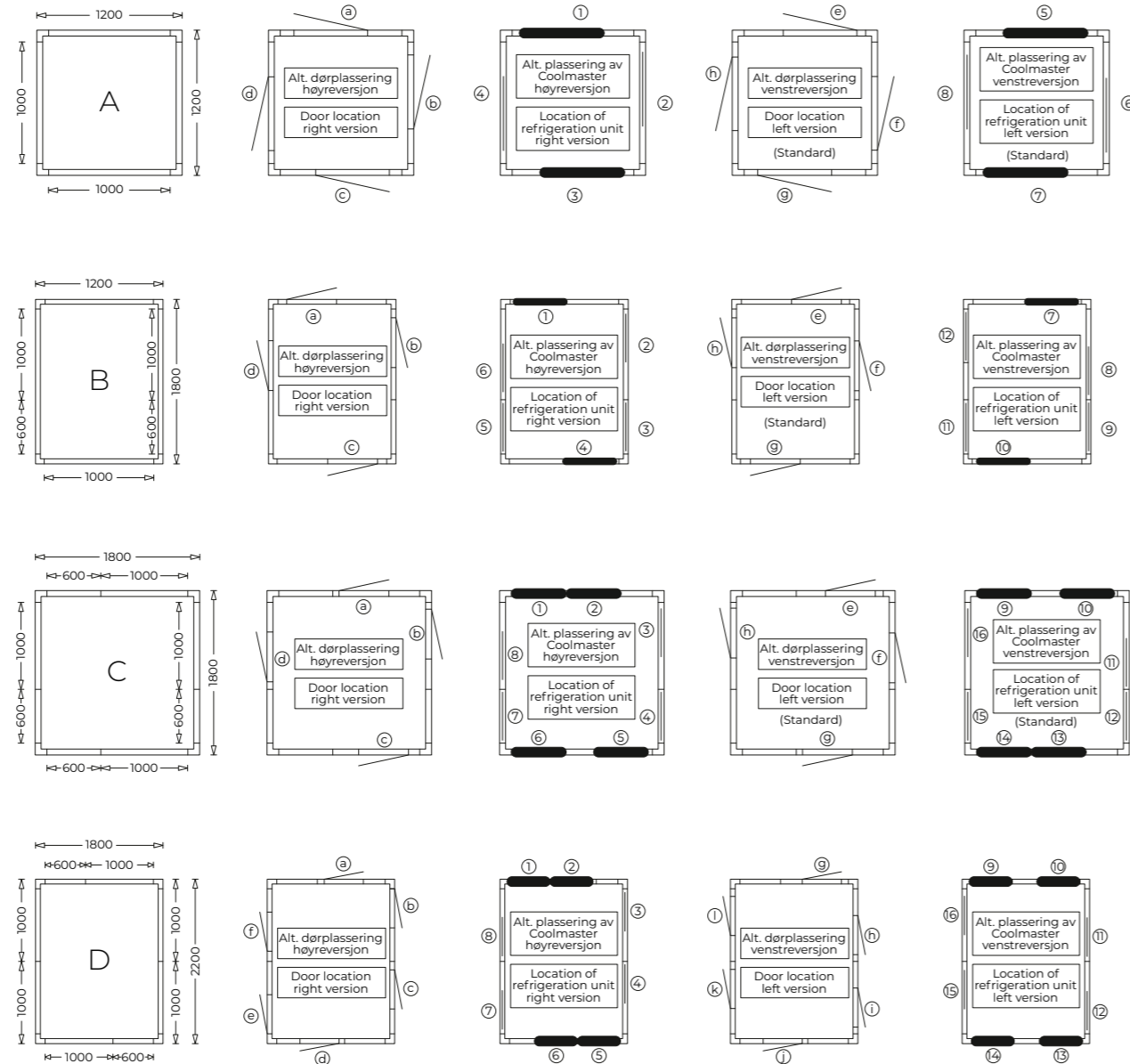

Room A

Item number	14152500
Width	120 cm
Depth	120 cm
Height	212 cm
Volume	2420 liters
Gross weight	156 kg

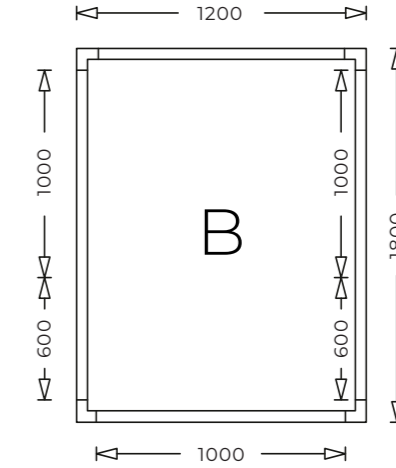

Room B

Item number	14153000
Width	120 cm
Depth	180 cm
Height	212 cm
Volume	3740 liters
Gross weight	211 kg

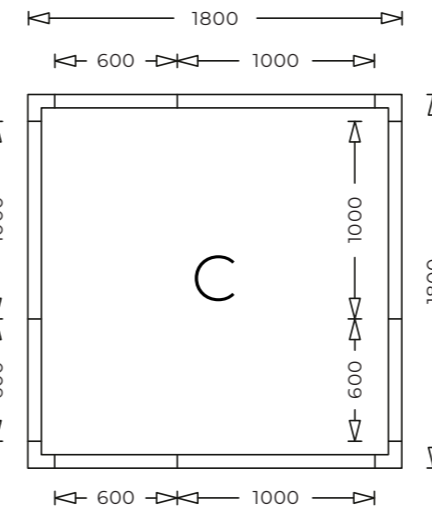

Room C

Item number	14154000
Width	180 cm
Depth	180 cm
Height	212 cm
Volume	5780 liters
Gross weight	269 kg

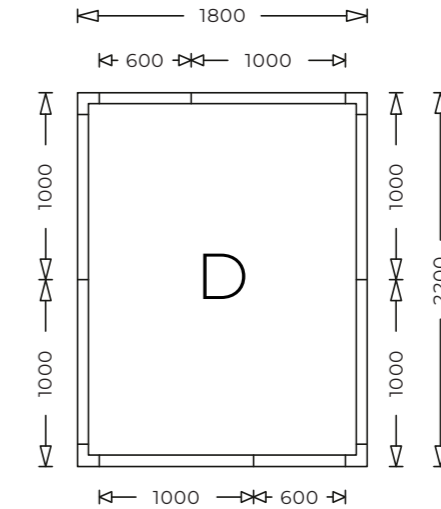

Room D

Item number	14154200
Width	220 cm
Depth	180 cm
Height	212 cm
Volume	7140 liters
Gross weight	304 kg

Scandinavian Appliances AS

Postboks 61
1740 Borgenhaugen
Norway

Phone number: +47 815 69 117
E-mail: post@norcool.no

en.norcool.com

Visit our website for more
information and user manuals.

Follow us on social media

 [scandinavianappliancesnorcool](https://www.facebook.com/scandinavianappliancesnorcool)

 [norcool.appliances](https://www.instagram.com/norcool.appliances)

norcool