

Project	_____
Item	_____
Quantity	_____
Date	_____

Model
Unox Model 1S

Combi oven	Electric
4 trays GN 1/1	Hinge on the left side
9.5" Touch control panel	



Description

SuperOven Model 1S is the compact, single-cooking-chamber version of our high-performance oven. It incorporates the same cutting-edge technology and innovation as our professional models but is tailored for private kitchen environments.

The oven excels in delivering exceptional cooking performance, offering a diverse array of cooking methods, including grilling, frying, smoking, dehydrating, steaming, and sous vide. Notably, the inclusion of humidity sensors enhances cooking efficiency, resulting in consistent and rapid cooking processes, up to three times faster than conventional ovens. The digital interface is user-friendly, granting access to a vast library of over 400 automatic cooking programmes that adapt settings based on food quantity, ensuring precision in cooking. The integrated ventilation system features professional-grade active carbon filters, effectively eliminating odours and vapours. Additionally, the oven incorporates a self-cleaning function that simplifies maintenance, utilising a water-based solution infused with the company's proprietary eco-friendly detergent. For added convenience, Model 1S includes a sliding accessory drawer that neatly stores professional trays, detergent, and a smoker, enhancing the overall cooking experience.

Unox Intelligent Performance

- **SENSE.Klean:** estimates the degree of dirt of the oven and suggests the most suitable automatic washing
- **ADAPTIVE.Cooking™:** automatically adjusts the cooking parameters according to the food load to ensure repeatable results
- **CLIMALUX™:** continuous measurement and regulation of the real humidity present in the cooking chamber
- **SMART.Preheating:** automatically sets the temperature and duration of the preheating according to the previous modes of use

Unox Intensive Cooking

- **DRY.Maxi™:** quickly removes moisture from the cooking chamber
- **STEAM.Maxi™:** produces saturated steam
- **AIR.Maxi™:** multi-fan system with reversing
- **PRESSURE.Steam:** increases the steam saturation and temperature

Automatic and advanced cooking features

- **AUTO.COOK function:** automatic pre-set functions
- **MULTI.TIME function:** manages up to 10 cooking processes at the same time
- **SET function:** definition of cooking parameters: time/core probe, temperature (30-260°C), humidity/extraction, fan speed/pulsed fans
- **My Programs function:** library where you can save manually set cooking programs and add recipes from the web-based Cook Like A Chef catalogue.

XEVH-0511-EPRM

Key features

- **ROTOR.Klean™**: automatic washing system
- Cooking chamber in high-resistance AISI 304 stainless steel with rounded edges
- Triple glass
- Cooking chamber lighting through LED lights embedded in the door
- Tray supports with anti-tip system
- Tray supports with anti-tip system
- 4-speed fan system and high-performance heating elements
- Integrated DET&Rinse™ detergent container
- Integrated Wi-Fi
- **Wi-Fi data**: download programs
- **Web services**: Cook like a Chef

Included accessories

- **Ventless hood with activated carbon filter**: steam condensing hood with activated carbon filter
- **HYPER.Smoker**: smoker box for wood chips and sawdust to smoke inside the cooking chamber without extra electrical supply
- **Cooking Essentials**: UNOX Casa special trays.
BLACK.FRY - GRP816;
GRILL - TG885;
BLACK.40 - TG900;
STEEL.GRID - GPR806

XEVH-0511-EPRM



Option 1
Flush installation

Pag. 4 - 6



Option 2
Flush installation with XEVH-0511-R1 stand

Pag. 7 - 9

Option 1 - Flush installation**Information**

Prepare a circuit breaker in the electrical panel to be able to disconnect the power in case of need.

Arrange the water tap in an accessible location to be able to shut off the flow in case of need.

The equipment leaves the factory with the hood in the filtering version. If necessary during the installation phase it will be possible to convert the hood from filtering to extraction. See chimney dimensions on the next pages.

For further information, we invite you to consult the installation manual available on the Unox Casa website at the link below.

[> Installation manual](#)

Option 1 - Flush installation

Oven dimensions

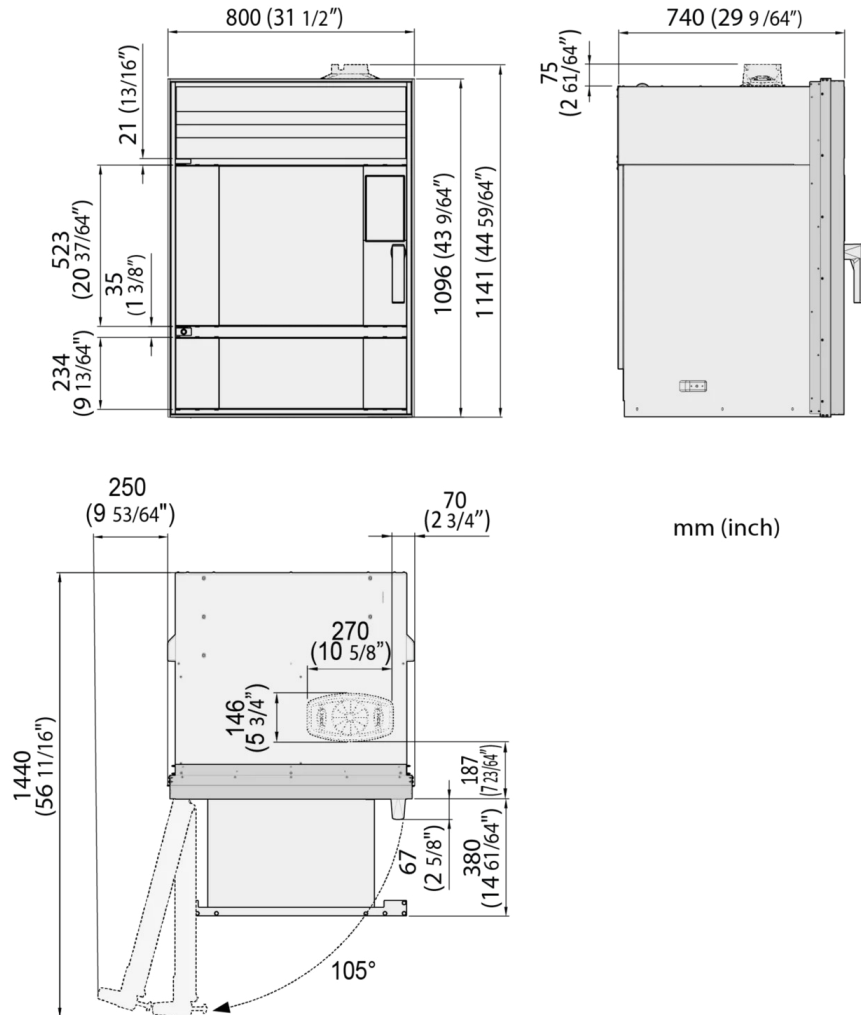

Dimensions and weight

Width	800 mm
Depth	740 mm
Height	1096 mm
Net weight	136 kg
Tray pitch	80 mm

Notes

To fully open the door (105°), necessary to insert/extract the trays, leave a space of 250 mm (9" 53/64 inch) starting from the side of the oven.

Option 1 - Flush installation

Built-in cabinet features

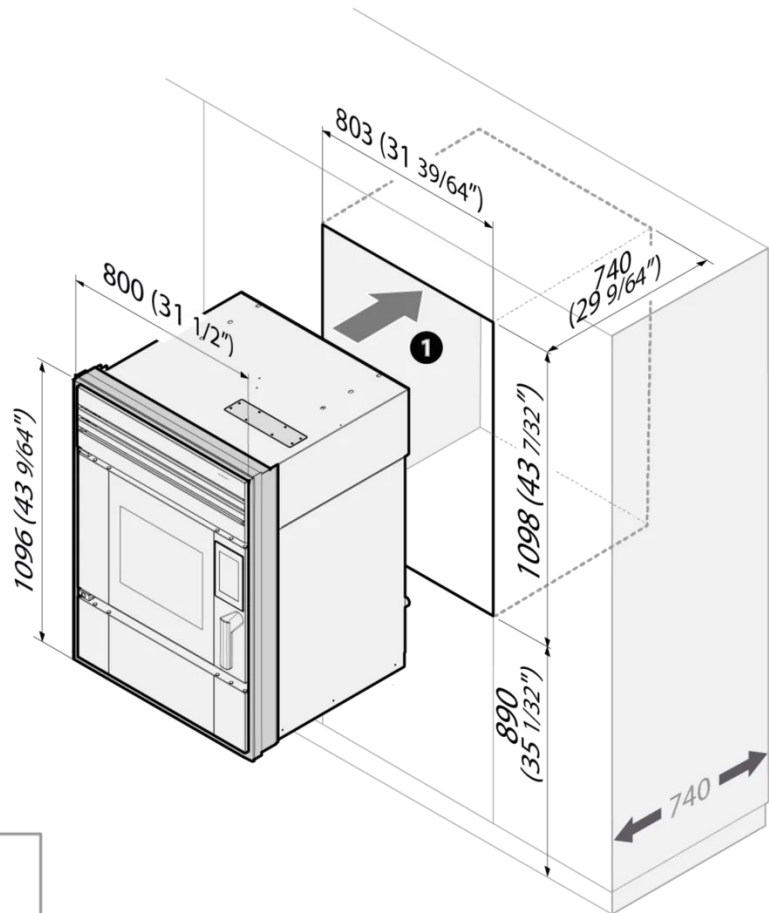

mm (inch)

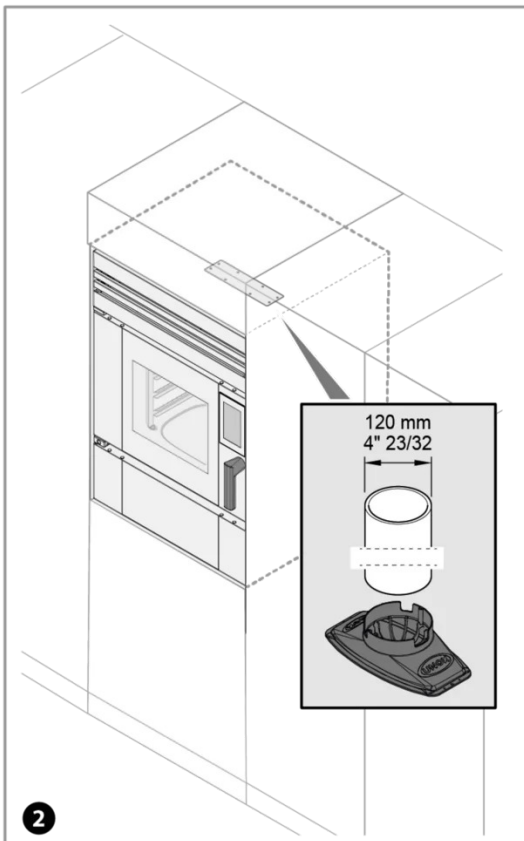

Notes

The following dimensions must be considered to fit the oven inside the cabinet.

Width + 3 mm

Depth + 0 mm

Height + 2 mm

For further information, we invite you to consult the installation manual available on the Unox Casa website at the link below.

Option 2 - Flush installation with XEVH-0511-R1 stand**Information**

The stand's structure allows for fitting a custom-made cabinet inside

The XEVH-0511-R1 stand allows the oven to be moved thanks to its integrated wheels.

Prepare a circuit breaker in the electrical panel to be able to disconnect the power in case of need.

Arrange the water tap in an accessible location to be able to shut off the flow in case of need.

The equipment leaves the factory with the hood in the filtering version. If necessary during the installation phase it will be possible to convert the hood from filtering to extraction. See chimney dimensions on the next pages.

For further information, we invite you to consult the installation manual available on the Unox Casa website at the link below.

[> Installation manual](#)

Option 2 - Flush installation with XEVH-0511-R1 stand

Oven dimensions with stand

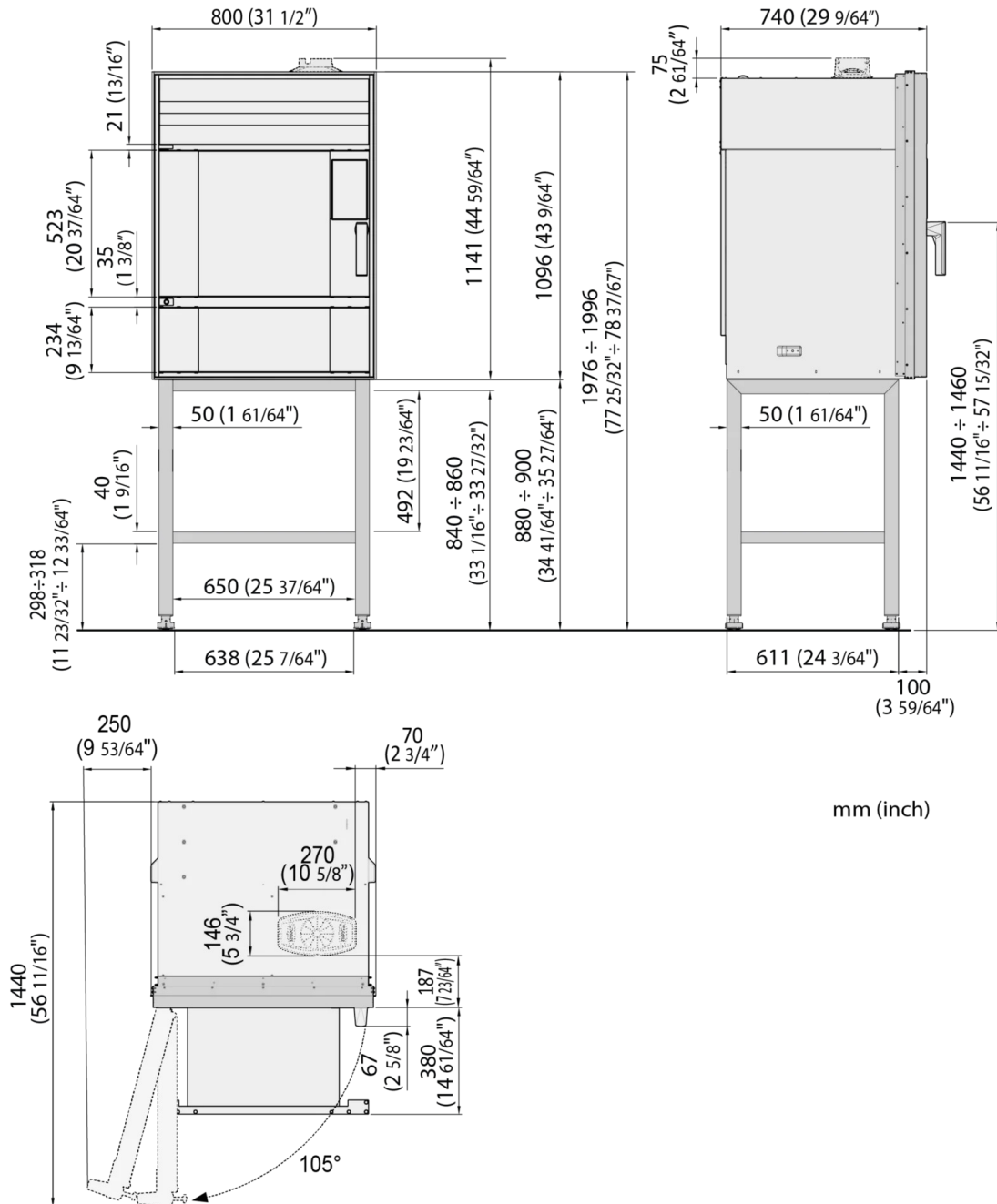

Dimensions and weight

Width	800 mm
Depth	740 mm
Height	1986 mm
Net weight	136 kg
Tray pitch	80 mm

Notes

To fully open the door (105°), necessary to insert/extract the trays, leave a space of 250 mm (9" 53/64 inch) starting from the side of the oven.

Option 2 - Flush installation with XEVH-0511-R1 stand

Built-in cabinet features with stand

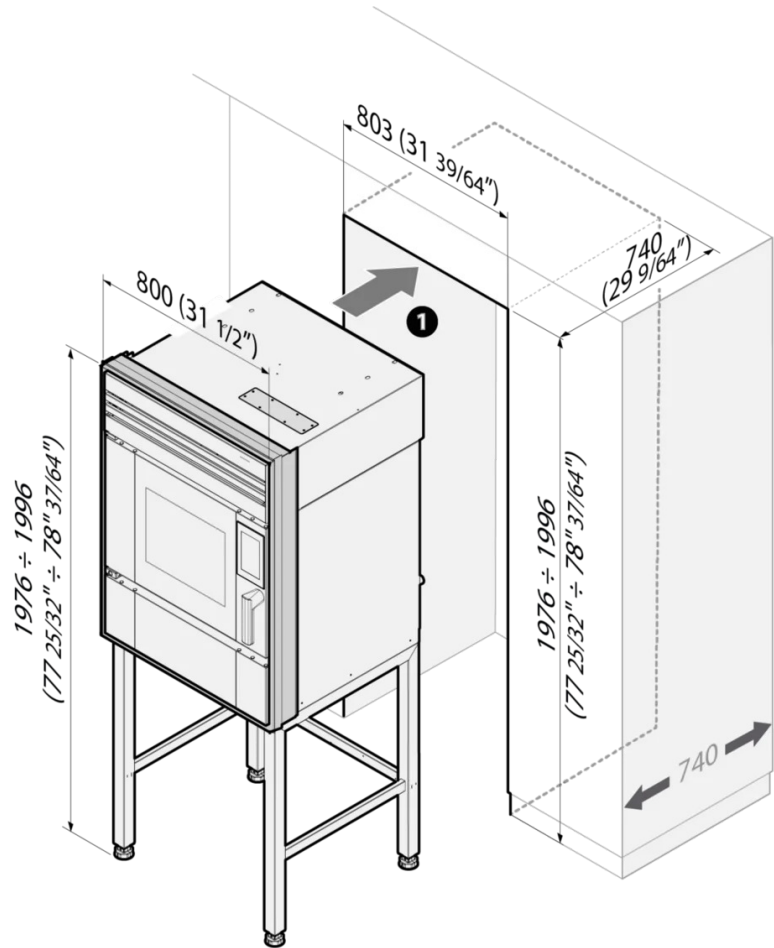

mm (inch)

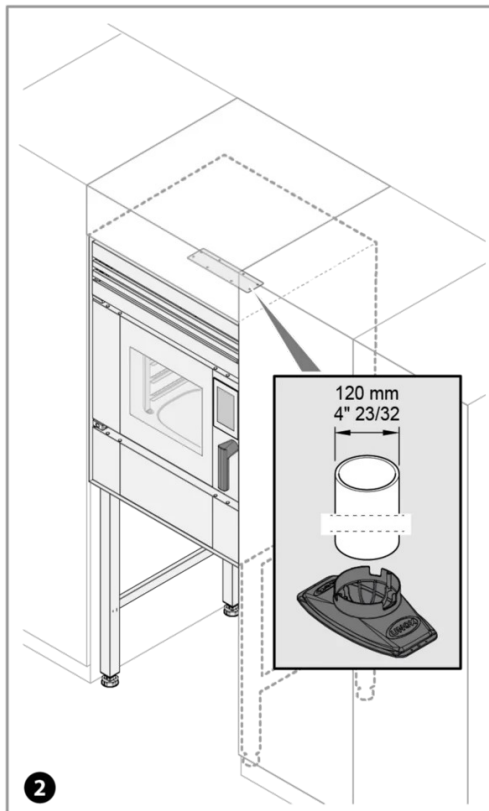

Notes

Thanks to the feet it will be possible to adjust the leveling and the final height of the oven.

For further information, we invite you to consult the installation manual available on the Unox Casa website at the link below.

Connection positions

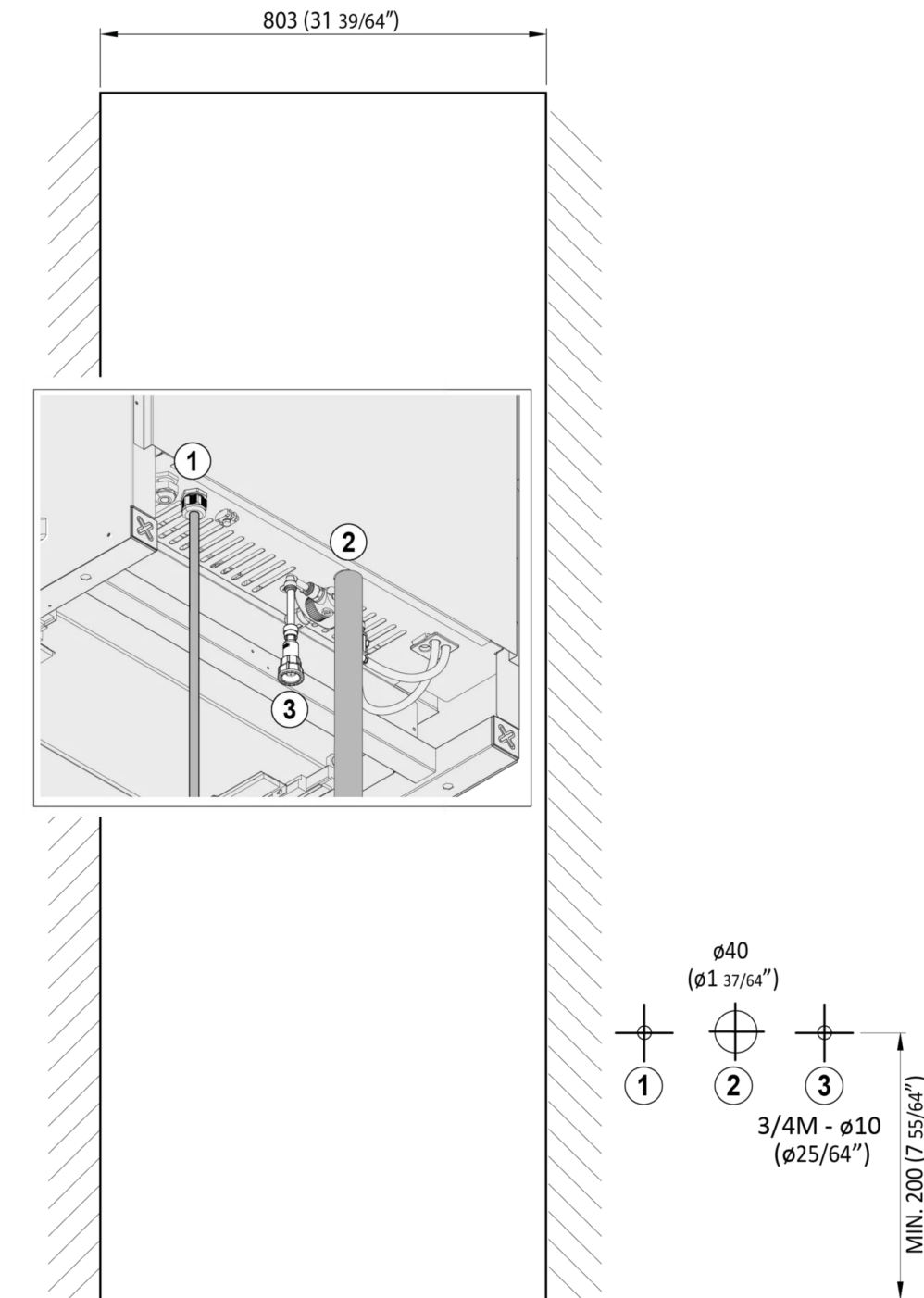

Connection positions

- 1 Electrical outlet
- 2 40mm liquids drain pipe
- 3 3/4 tap for column water supply

Electrical power supply

OPTION A

Voltage	380-415 V
Phase	~3PH+N+PE
Frequency	50 / 60 Hz
Total power	6.2 kW
Max Amp draw	11.5 A
Required breaker size	16 A
Power cable requirements*	5G x 2,5 mm ²
Plug	NOT INCLUDED

OPTION B

Voltage	220-240 V
Phase	~3PH+PE
Frequency	50 / 60 Hz
Total power	6.2 kW
Max Amp draw	17.5 A
Required breaker size	32 A
Power cable requirements*	4G x 4 mm ²
Plug	NOT INCLUDED

*Recommended size - observe local ordinance.

Water Supply

USING A WATER SUPPLY THAT DOES NOT MEET UNOX'S MINIMUM WATER QUALITY STANDARDS WILL VOID ANY WARRANTY.

It is the responsibility of the purchaser to ensure that the incoming water supply is compliant with the listed specifications through adequate treatment measures. One water tap per oven is required.

Drinking water inlet: 3/4" NPT, line pressure:

Line pressure: 1.5 to 6 Bar; 22 to 87 psi (2 Bar; 29 psi recommended)

Inflow water specifications

Free chlorine ≤ 0.5 ppm

Chloramine ≤ 0.1 ppm

pH 7 - 8.5

Electrical conductivity ≤ 1000 µS/cm

Total hardness ≤ 30° dH

Steam circuit: inflow water specifications

Chlorides ≤ 120 ppm

Total hardness ≤ 8 °dH*

*This value refers to daily steam cooking of 1-2 hours. In any case, if with a total hardness ≤ 8°dH there is still production of limescale, it is mandatory to treat the water in order to avoid limescale production. Unox recommends water treatment systems based on ion exchange resins. Water treatment systems based on polyphosphate are not allowed.

Installation requirements

Installations must comply with all local electrical systems, particularly as for minimum wire gauge required for field connection, hydraulic and ventilation supply.