

Project	_____
Item	_____
Quantity	_____
Date	_____

**Model**  
**Unox Model 1**

Combi oven	Electric
4 + 4 trays GN 1/1	Hinge on the left side
9.5" Touch control panel	



**Description**

SuperOven Model 1 is a dual-chamber, high-performance oven designed for professional-grade cooking in residential kitchens, offering the power and versatility of two professional ovens in one sleek column.

The oven excels in delivering exceptional cooking performance, offering a diverse array of cooking methods, including grilling, frying, smoking, dehydrating, steaming, and sous vide. Notably, the inclusion of humidity sensors enhances cooking efficiency, resulting in consistent and rapid cooking processes, up to three times faster than conventional ovens. The digital interface is user-friendly, granting access to a vast library of over 400 automatic cooking programmes that adapt settings based on food quantity, ensuring precision in cooking. The integrated ventilation system features professional-grade active carbon filters, effectively eliminating odours and vapours. Additionally, the oven incorporates a self-cleaning function that simplifies maintenance, utilising a water-based solution infused with the company's proprietary eco-friendly detergent. For added convenience, Model 1 includes a sliding accessory drawer that neatly stores professional trays, detergent, and a smoker, enhancing the overall cooking experience.

**Unox Intelligent Performance**

- **SENSE.Klean:** estimates the degree of dirt of the oven and suggests the most suitable automatic washing
- **ADAPTIVE.Cooking™:** automatically adjusts the cooking parameters according to the food load to ensure repeatable results
- **CLIMALUX™:** continuous measurement and regulation of the real humidity present in the cooking chamber
- **SMART.Preheating:** automatically sets the temperature and duration of the preheating according to the previous modes of use

**Unox Intensive Cooking**

- **DRY.Maxi™:** quickly removes moisture from the cooking chamber
- **STEAM.Maxi™:** produces saturated steam
- **AIR.Maxi™:** multi-fan system with reversing
- **PRESSURE.Steam:** increases the steam saturation and temperature

**Automatic and advanced cooking features**

- **AUTO.COOK function:** automatic pre-set functions
- **MULTI.TIME function:** manages up to 10 cooking processes at the same time
- **SET function:** definition of cooking parameters: time/core probe, temperature (30-260°C), humidity/extraction, fan speed/pulsed fans
- **My Programs function:** library where you can save manually set cooking programs and add recipes from the web-based Cook Like A Chef catalogue.

# XEVH-5511-EPRM

## Key features

- **ROTOR.Klean™**: automatic washing system
- Cooking chamber in high-resistance AISI 304 stainless steel with rounded edges
- Triple glass
- Cooking chamber lighting through LED lights embedded in the door
- Tray supports with anti-tip system
- Tray supports with anti-tip system
- 4-speed fan system and high-performance heating elements
- Integrated DET&Rinse™ detergent container
- Integrated Wi-Fi
- **Wi-Fi data**: download programs
- **Web services**: Cook like a Chef

## Included accessories

- **Ventless hood with activated carbon filter**: steam condensing hood with activated carbon filter
- **HYPER.Smoker**: smoker box for wood chips and sawdust to smoke inside the cooking chamber without extra electrical supply
- **Cooking Essentials**: UNOX Casa special trays.  
BLACK.FRY - GRP816;  
EGGS 8 - TG936;  
GRILL - TG885;  
FAKIRO.GRILL - TG870;  
BLACK.40 - TG900;  
FORO.BLACK - TG890;  
STEEL.GRID - GPR806

# XEVH-5511-EPRM



**Option 1**

Flush installation with XUC502 steel frame

Pag. 4 - 6



**Option 2**

Non-flush installation with XUC501 steel frame

Pag. 7 - 9

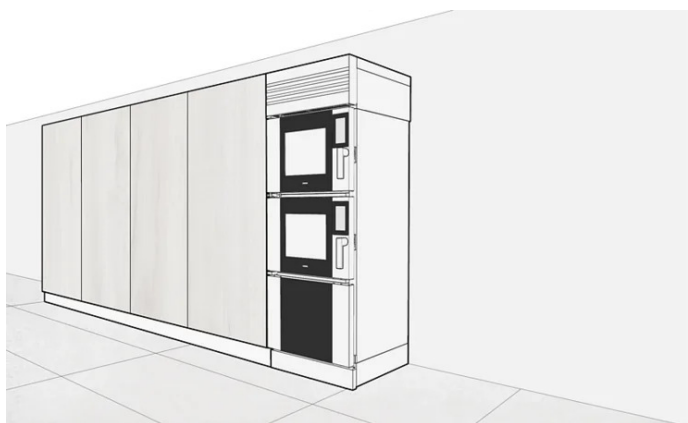

**Option 3**

Freestanding installation with XUC511 kit

Pag. 10 - 11

**Option 1 - Flush installation with XUC502 steel frame****Information**

The XUC502 frame is attached directly to the oven, and subsequently, the oven and frame are inserted into the kitchen cabinet.

Prepare a circuit breaker in the electrical panel to be able to disconnect the power in case of need.

Arrange the water tap in an accessible location to be able to shut off the flow in case of need.

The equipment leaves the factory with the hood in the filtering version. If necessary during the installation phase it will be possible to convert the hood from filtering to extraction. See chimney dimensions on the next pages.

For further information, we invite you to consult the installation manual available on the Unox Casa website at the link below.

[> Installation manual](#)

**Option 1 - Flush installation with XUC502 steel frame**

**Oven dimensions with applied frame**

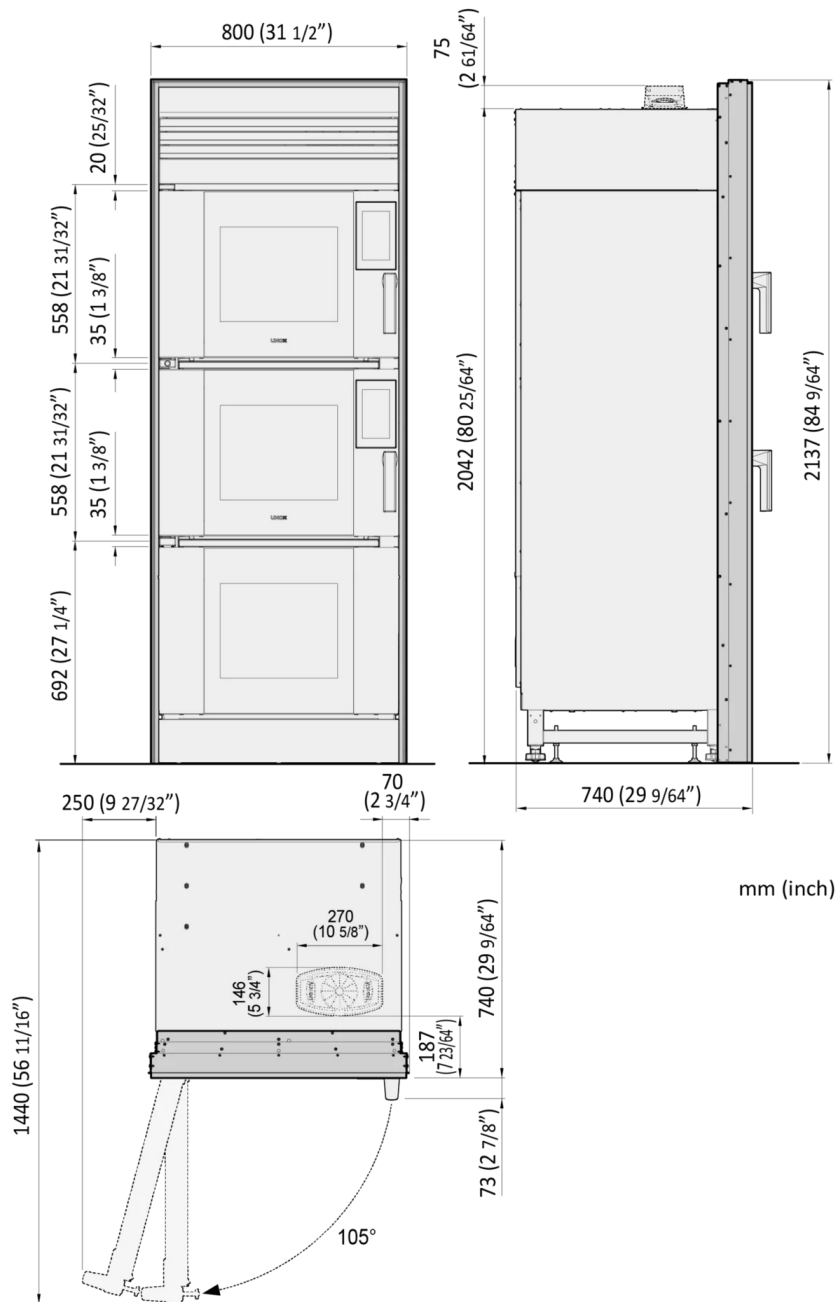

mm (inch)

**Dimensions and weight**

<b>Width</b>	800 mm
<b>Depth</b>	740 mm
<b>Height</b>	2137 mm
<b>Net weight</b>	230 kg
<b>Tray pitch</b>	80 mm

**Notes**

To fully open the door (105°), necessary to insert/extract the trays, leave a space of 250 mm (9" 53/64 inch) starting from the side of the oven.

**Option 1 - Flush installation with XUC502 steel frame**

**Built-in cabinet features**

**Notes**

The following dimensions must be considered to fit the oven inside the cabinet.

Width + 3 mm

Depth + 0 mm

Height + 0 mm

Thanks to the feet, it will be possible to adjust the final height of the oven. Once the oven is inserted into the cabinet, it should be leveled using the adjustable feet.

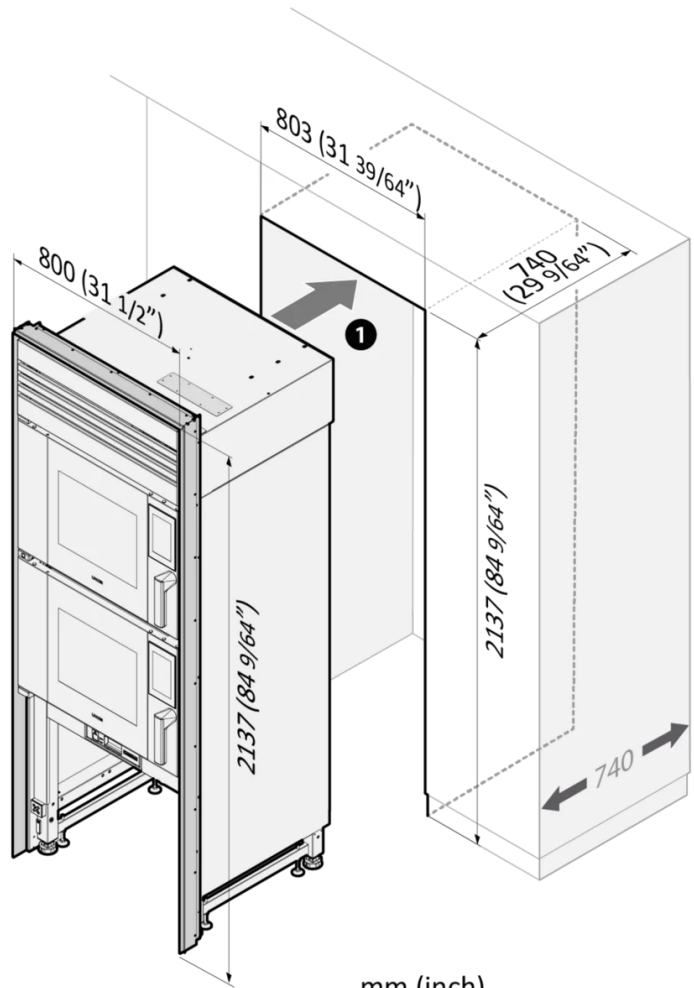

mm (inch)

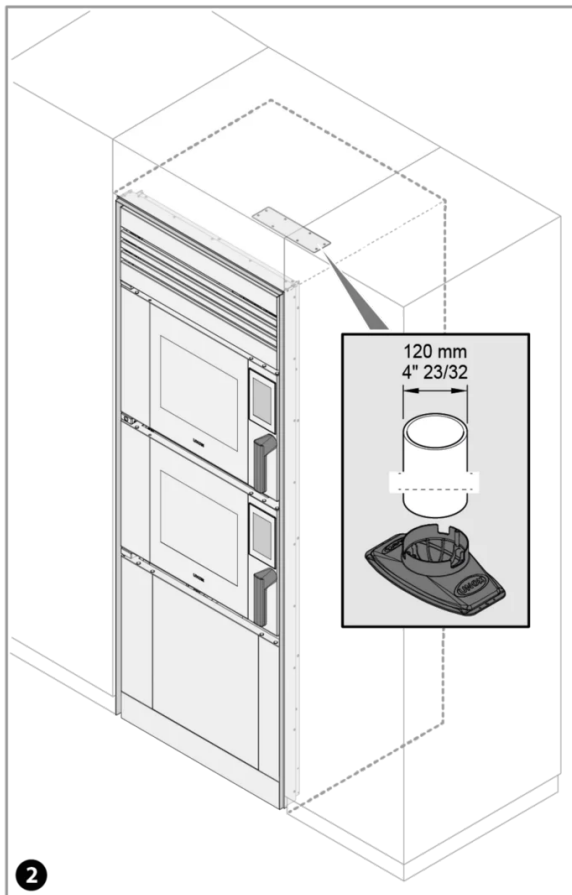

**Option 2 - Non-flush installation with XUC501 steel frame****Information**

The XUC501 frame is fixed to the kitchen cabinet and then the oven is inserted inside the cabinet.

Prepare a circuit breaker in the electrical panel to be able to disconnect the power in case of need.

Arrange the water tap in an accessible location to be able to shut off the flow in case of need.

The equipment leaves the factory with the hood in the filtering version. If necessary during the installation phase it will be possible to convert the hood from filtering to extraction. See chimney dimensions on the next pages.

For further information, we invite you to consult the installation manual available on the Unox Casa website at the link below.

[> Installation manual](#)

**Option 2 - Non-flush installation with XUC501 steel frame**

**Oven dimensions with applied frame**

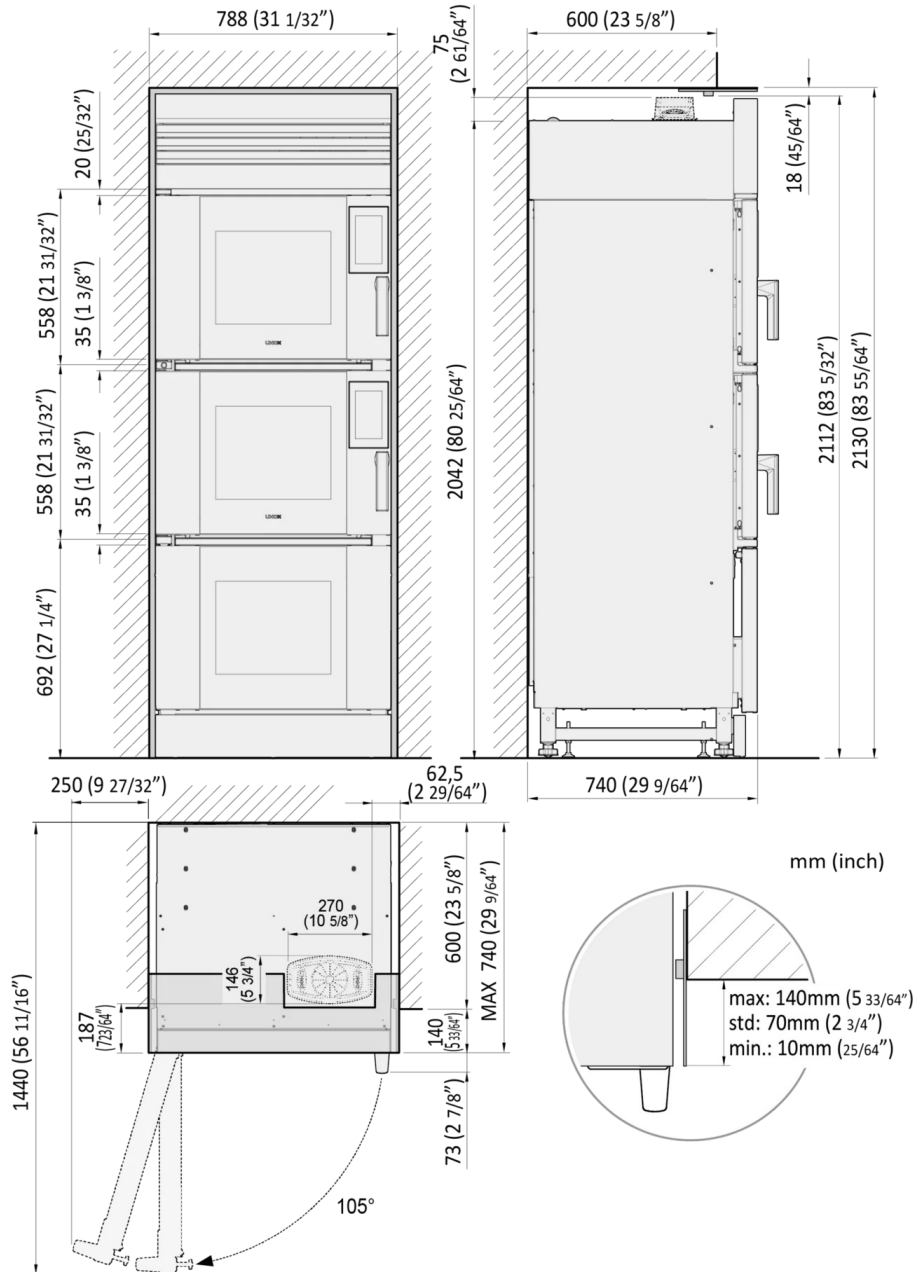

**Dimensions and weight**

Width	788 mm
Depth	740 mm
Height	2130 mm
Net weight	230 kg
Tray pitch	80 mm

**Notes**

To fully open the door (105°), necessary to insert/extract the trays, leave a space of 250 mm (9" 53/64 inch) starting from the side of the oven.

**Option 2 - Non-flush installation with XUC501 steel frame**

**Built-in cabinet features**

**Notes**

The frame will be fixed to the kitchen cabinet.

The oven will be inserted into the designated niche.

Thanks to the feet it will be possible to adjust the leveling and the final height of the oven. The frame can be installed a maximum of 140 mm from the edge of the kitchen cabinet.

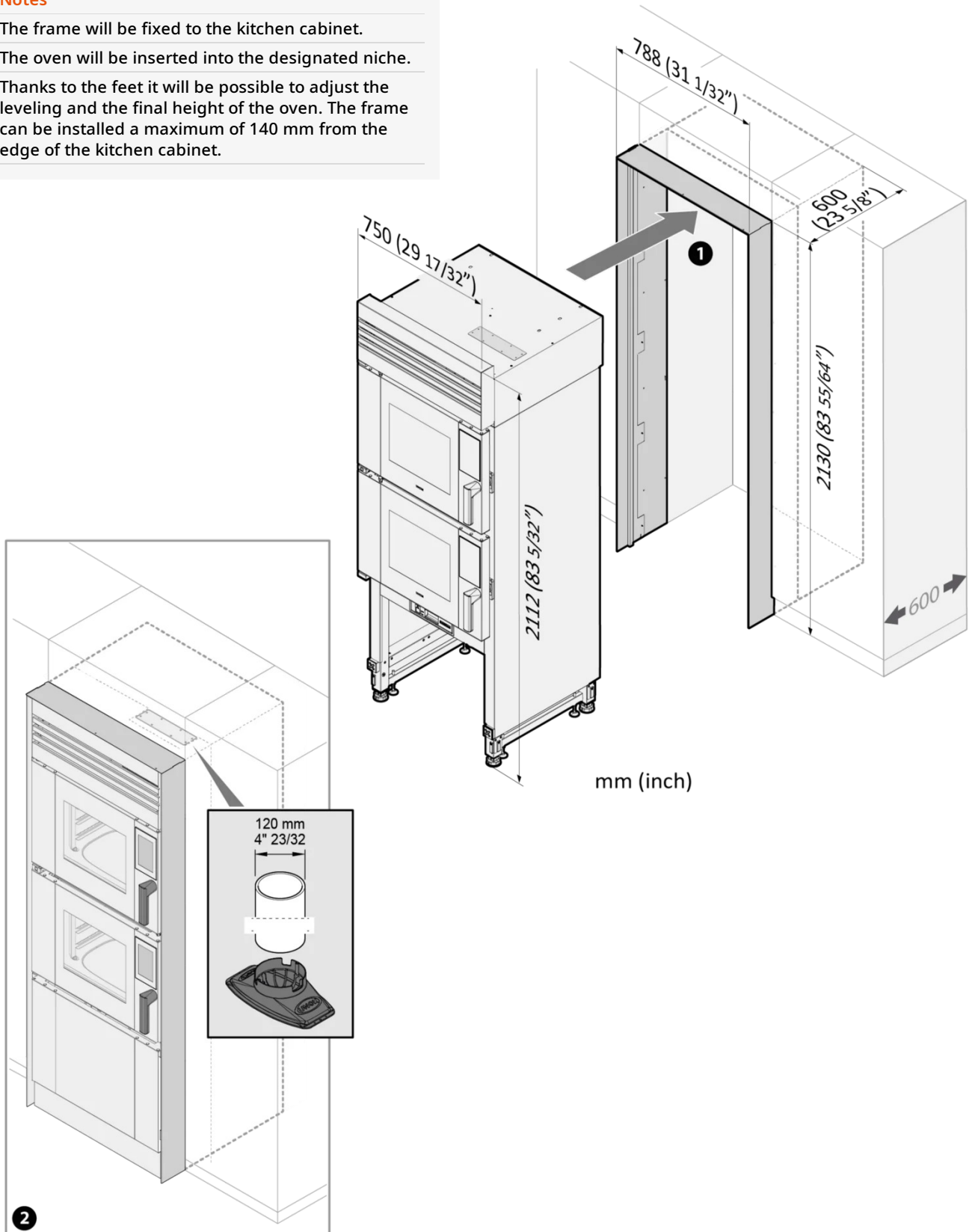

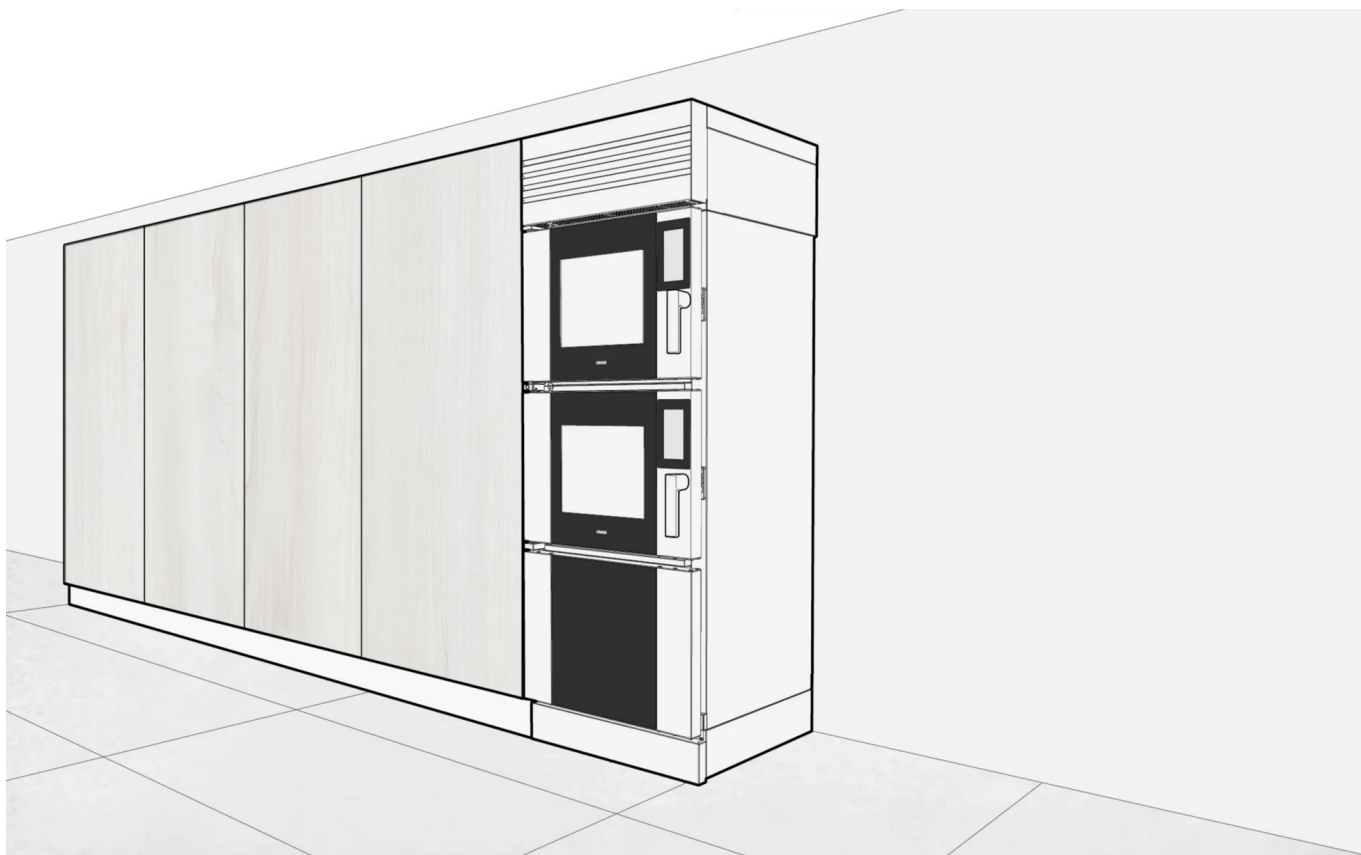
**Option 3 - Freestanding installation with XUC511 kit**

For further information, we invite you to consult the installation manual available on the Unox Casa website at the link below.

[> Installation manual](#)

**Option 3 - Freestanding installation with XUC511 kit**



**Dimensions and weight**

<b>Width</b>	750 mm
<b>Depth</b>	735 mm
<b>Height</b>	2112 mm
<b>Net weight</b>	230 kg
<b>Tray pitch</b>	80 mm

**Notes**

To fully open the door (105°), necessary to insert/extract the trays, leave a space of 250 mm (9" 53/64 inch) starting from the side of the oven.

Connection positions

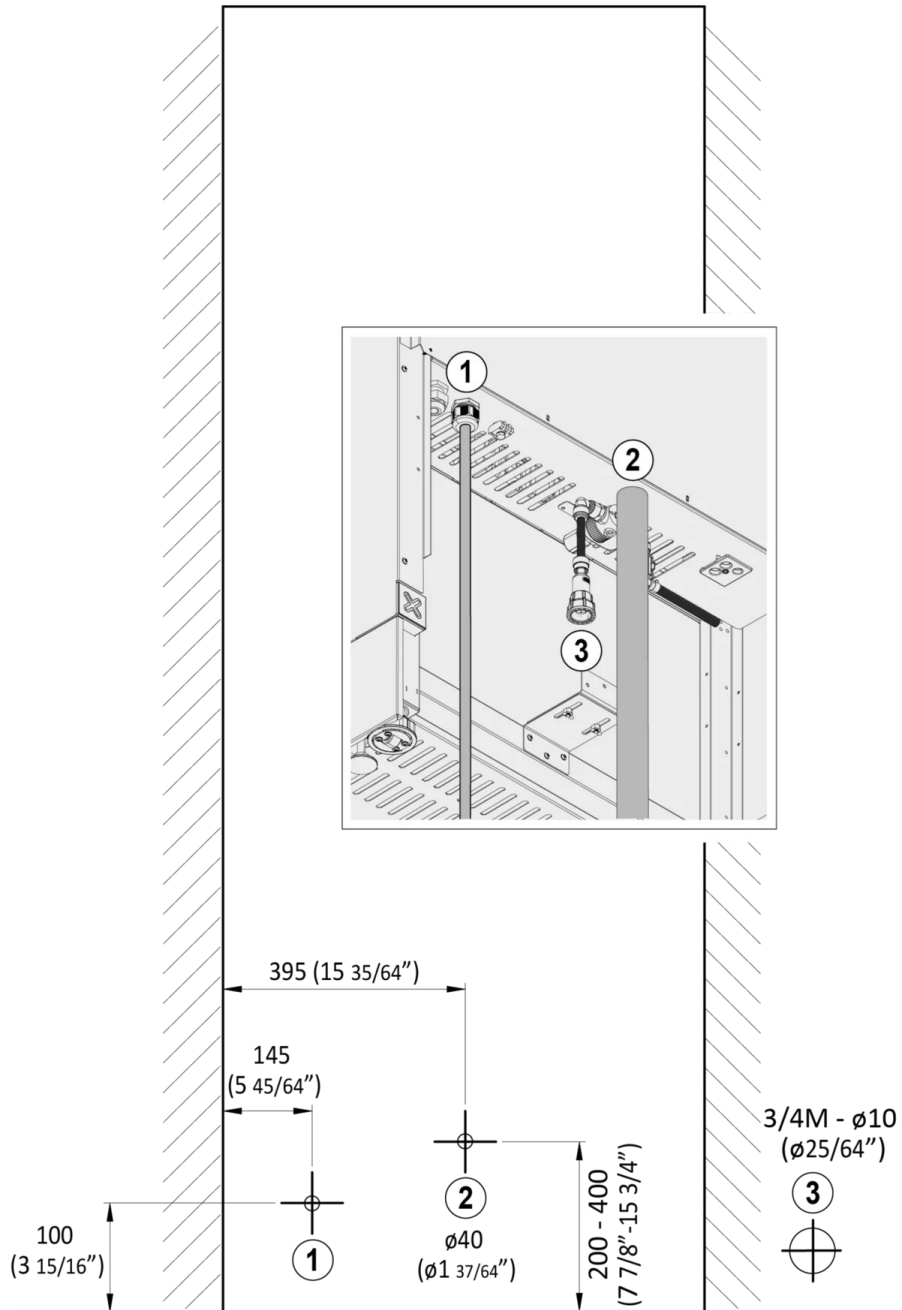

Connection positions

- 1 32A electrical outlet, absorption 10kW-400V 3PH+N+PE
- 2 40mm liquids drain pipe
- 3 3/4 tap for column water supply

## Electrical power supply

### OPTION A

<b>Voltage</b>	380-415 V
<b>Phase</b>	~3PH+N+PE
<b>Frequency</b>	50 / 60 Hz
<b>Total power</b>	10.0 kW
<b>Max Amp draw</b>	17.5 A
<b>Required breaker size</b>	32 A
<b>Power cable requirements*</b>	5G x 4 mm <sup>2</sup>
<b>Plug</b>	IEC309 3P+N+PE 400V 32A H6 IP67

### OPTION B

<b>Voltage</b>	220-240 V
<b>Phase</b>	~3PH+PE
<b>Frequency</b>	50 / 60 Hz
<b>Total power</b>	10.0 kW
<b>Max Amp draw</b>	26.5 A
<b>Required breaker size</b>	32 A
<b>Power cable requirements*</b>	4G x 4 mm <sup>2</sup>
<b>Plug</b>	IEC309 3P+N+PE 400V 32A H6 IP67

### OPTION C

<b>Voltage</b>	220-240 V
<b>Phase</b>	~1PH+PE
<b>Frequency</b>	50 / 60 Hz
<b>Total power</b>	10.0 kW
<b>Max Amp draw</b>	43.5 A
<b>Required breaker size</b>	50 A
<b>Power cable requirements*</b>	3G x 6 mm <sup>2</sup>
<b>Plug</b>	IEC309 3P+N+PE 400V 32A H6 IP67

\*Recommended size - observe local ordinance.

## Water Supply

USING A WATER SUPPLY THAT DOES NOT MEET UNOX'S MINIMUM WATER QUALITY STANDARDS WILL VOID ANY WARRANTY.

It is the responsibility of the purchaser to ensure that the incoming water supply is compliant with the listed specifications through adequate treatment measures. One water tap per oven is required.

Drinking water inlet: 3/4" NPT, line pressure:

**Line pressure:** 1.5 to 6 Bar; 22 to 87 psi (2 Bar; 29 psi recommended)

### Inflow water specifications

**Free chlorine** ≤ 0.5 ppm

**Chloramine** ≤ 0.1 ppm

**pH** 7 - 8.5

**Electrical conductivity** ≤ 1000 µS/cm

**Total hardness** ≤ 30° dH

### Steam circuit: inflow water specifications

**Chlorides** ≤ 120 ppm

**Total hardness** ≤ 8 °dH\*

\*This value refers to daily steam cooking of 1-2 hours. In any case, if with a total hardness ≤ 8°dH there is still production of limescale, it is mandatory to treat the water in order to avoid limescale production. Unox recommends water treatment systems based on ion exchange resins. Water treatment systems based on polyphosphate are not allowed.

### Installation requirements

Installations must comply with all local electrical systems, particularly as for minimum wire gauge required for field connection, hydraulic and ventilation supply.